

GK – 01

# GO-KART

NAVODILA ZA SESTAVLJANJE

---

# DOCYKE



Čas izdelave: 6h  
Največja dovoljena teža: 70kg

# DOCYKE

---

Preden začnete sestavljati in uporabljati naš izdelek vas prosimo, da pozorno preberete varnostno opozorilo in prenesete navodila z naše spletne strani: [www.docyke.shop](http://www.docyke.shop)

## **Pozor!**

Vozilo mora sestaviti odrasla oseba ali oseba pod nadzorom odrasle osebe.

## **POZOR!**

Uporabljajte pod nadzorom odrasle osebe. Starši ali skrbniki se morajo seznaniti z sledečimi opozorili in navodili še preden se sestavi katerokoli izmed vozil. Vaša odgovornost je, da se seznanite s temi informacijami in da poskrbite da vsi uporabniki vozil razumejo vsa opozorila, navodila in varnostna priporočila in da mladim voznikom omogočite varno in odgovorno uporabo tega izdelka. Priporočamo vam, da redno pregledate in utrdite vsebino teh navodil z mladimi uporabniki izdelka in da poskrbite za redne preglede in vzdrževanje vozil za zagotovitev varnosti.

Vozila, ki jih lahko najdete v naših navodilih so bila testirana s strani neodvisnih testnih agencij. Nismo odgovorni, neposredno ali posredno, na kakršenkoli način, za kakršnokoli izgubo ali škodo ki nastane kot posledica sestavljanja vozil, ki ne sledijo navodilom oziroma le-teh v naših navodilih ni.

## Docyke navodila za uporabo:

- 1) Redno preglejte če so vsi deli čvrsto priviti in delujejo pravilno.
- 2) Nikoli ne presežite največje dovoljene teže oz. sile privijanja (15Nm). Največjo dovoljeno težo za vsako vozilo lahko najdete v naših navodilih.

- 3) Izogibajte se uporabi na ulicah in presežno izpostavljenost soncu, vodi, pesku, makedamu in ostalim delcem ki skrajšajo življensko dobo Docyke vozil.
- 4) Izogibajte se ostrim izboklinam, drenažnim rešetkam in nenadnim spremembam površin. Uporabljajte na gladkih, tlakovanih površinah.
- 5) Pred sestavljanjem seznanite otroke, mlajše od treh let z nevarnostjo zadržitve. Pazljivo odprite in sestavite vozila in tako poskrbite, da bodo vsi majhni delci in plastične vrečke izven dosega majhnih/ mlajših otrok.
- 6) Blato, listje in ostali delci lahko poškodujejo, skrčijo, razširijo ali oslabijo Docyke dele. Hranite in uporabljajte v suhem okolju.
- 7) Večina Docyke delov je narejeno samo za Docyke vozila. Naprošamo vas, da ne mešate s podobnimi deli s trga.
- 8) Poskrbite, da so pnevmatike napolnjene pod pritiskom do 2,3bar (priporočeni pritisk je 1.8bar).
- 9) Nosite primerna oblačila. Ne nosite ohlapnih oblačil ali nakita. Poskrbite da se vaši lasje, oblačila in rokavice ne dotikajo premikajočih delov. Izogibajte se stiku le-teh.
- 10) Uporabite zaščitno opremo. Vedno nosite zaščitno opremo ko so protizdrsni čevlji, čelada, komolčniki in kolenčniki, itd...
- 11) Odklopite baterijo od vozila pred karšnimikoli prilagoditvami, menjavami dodatkov, shranjevanjem ali neuporabi Docyke vozil.

### **Električno varnostno opozorilo:**

Preberite opozorila, navodila in jim dosledno sledite. Če tega ne storite, lahko pride do električnega udara, požara ali resnih poškodb.

- 1) Li baterijo polnite samo v zaprtih prostorih, ki so čisti in dobro osvetljeni. Ne izpostavljajte Docyke dežju ali mokrem okolju.

- 2) Polnite samo z polnilcem in priklopnim ohišjem, ki je bil specifično narejen izključno za Docyke.
- 3) Ko Li baterije ne uporabljate, jo hranite ločeno od kovinskih predmetov, ki lahko povzročijo kratek stik na Li bateriji in posledično električnega udara, opeklin in požara.
- 4) Ne odpirajte ali kakorkoli poškodujte ohišja Li baterije in polnilca, ker obstaja nevarnost kratkega stika. Ne izpostavljajte Li baterije vročini, soncu, ognju, vodi in vlagi. Obstaja nevarnost požara in eksplozije.

Za več informacij nas obiščite na  
[www.docyke.shop](http://www.docyke.shop)

## PRIPOROČENA ORODJA



Imbusni ključ



Ročaj za ključ

**DOCYKE** 多可



1

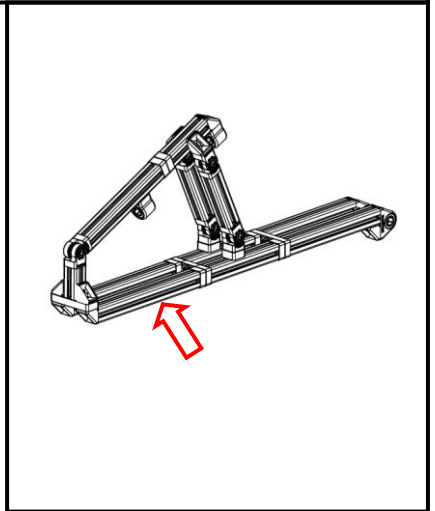
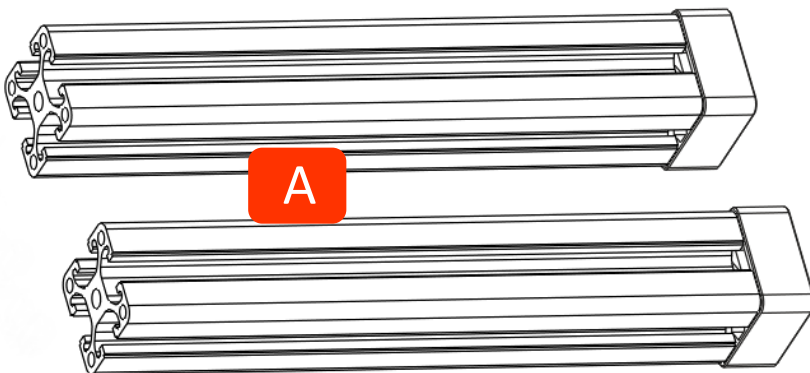
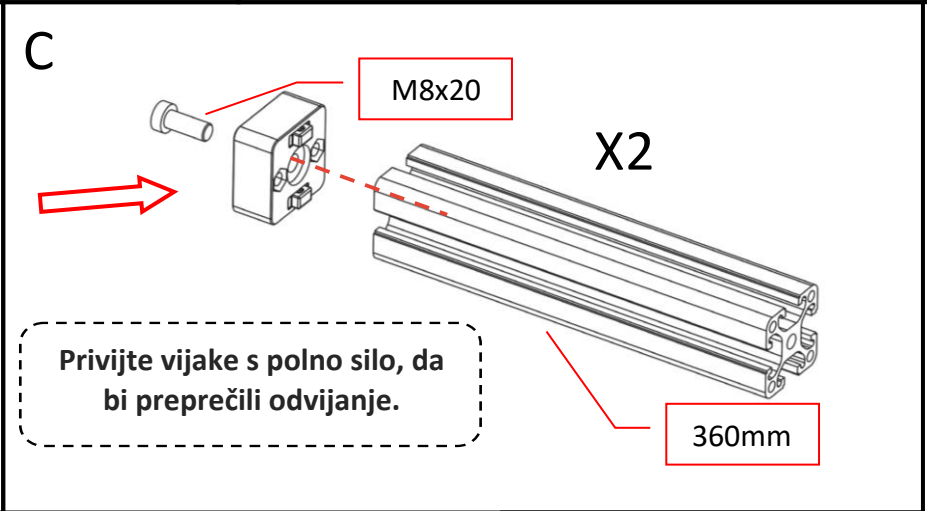
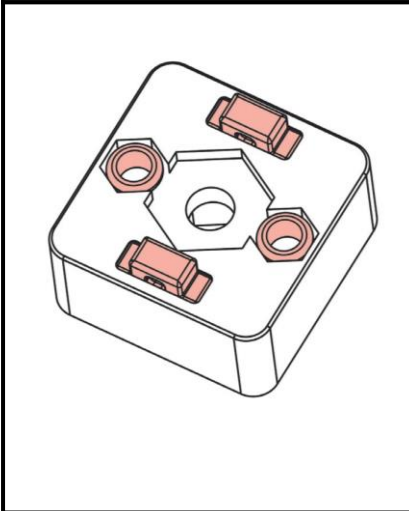
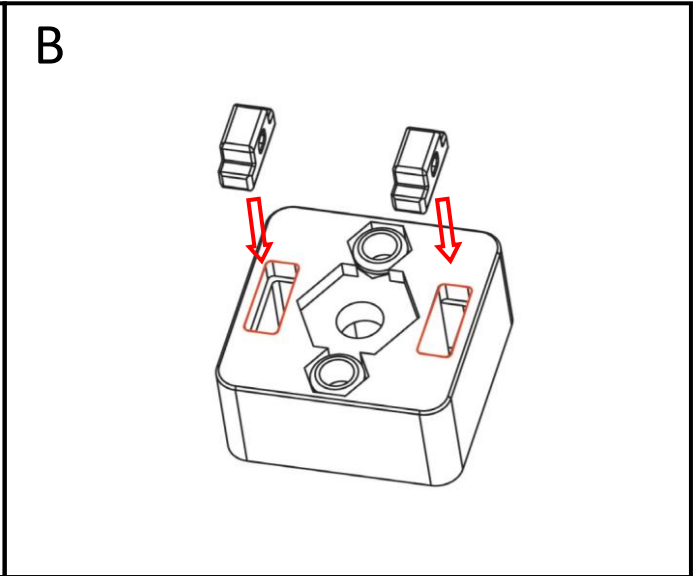
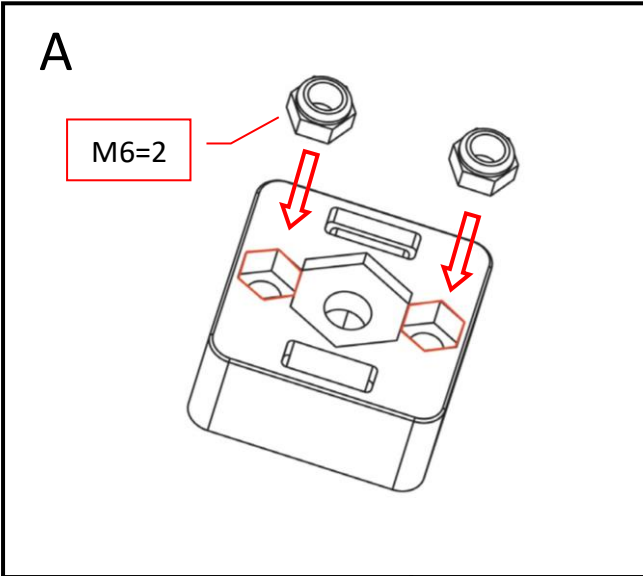

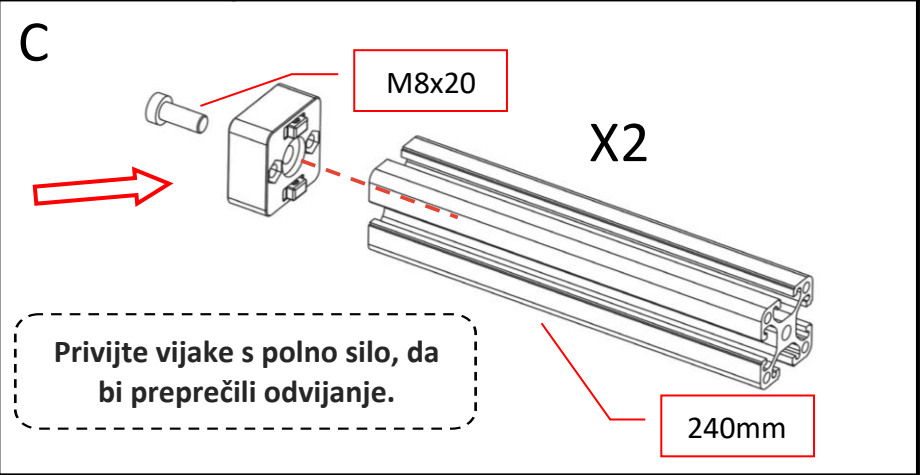
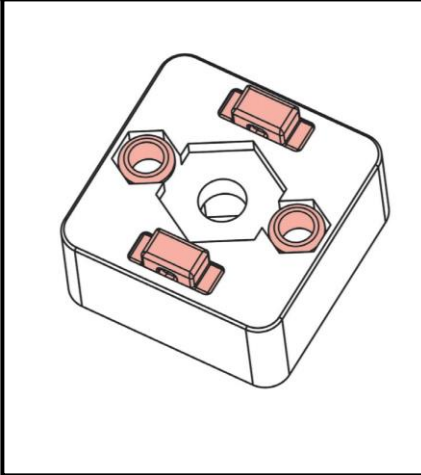
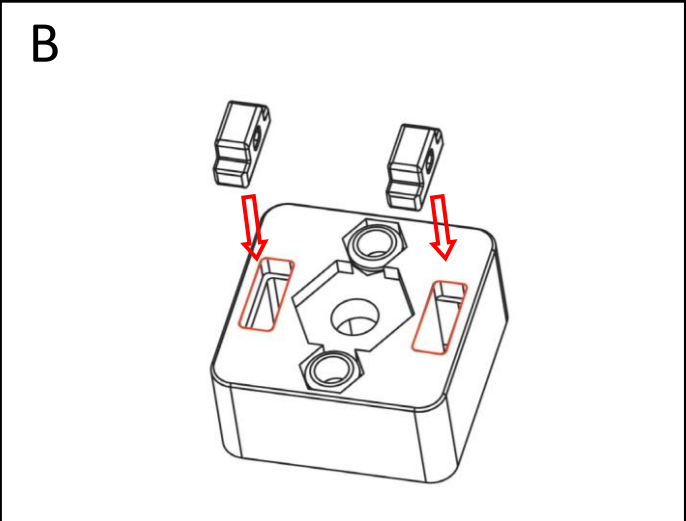
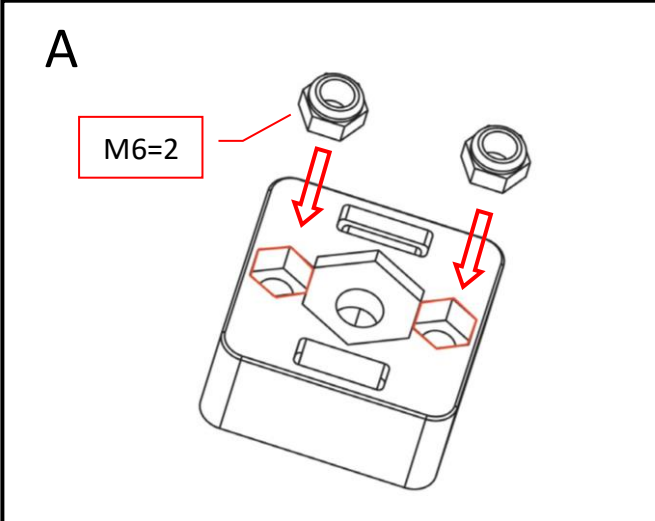
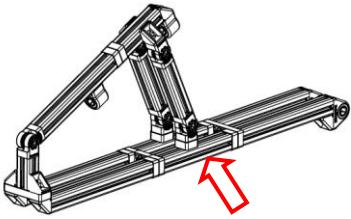

Plastični distančniki so med najmanjšimi a najpomembnejšimi deli. Pravilna postavitev le teh je ključnega pomena.

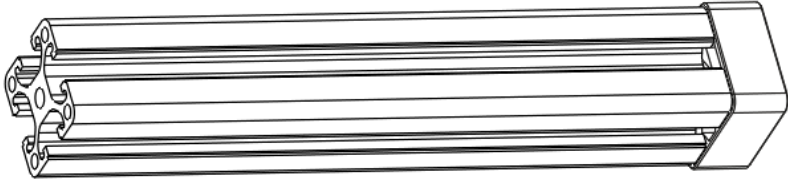
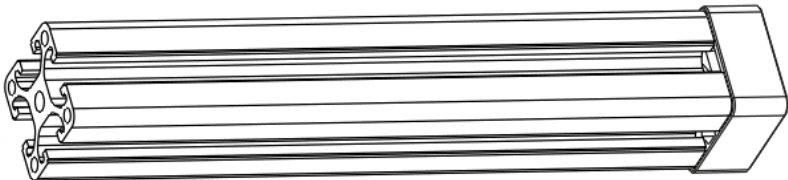
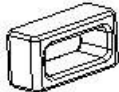
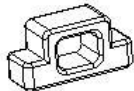

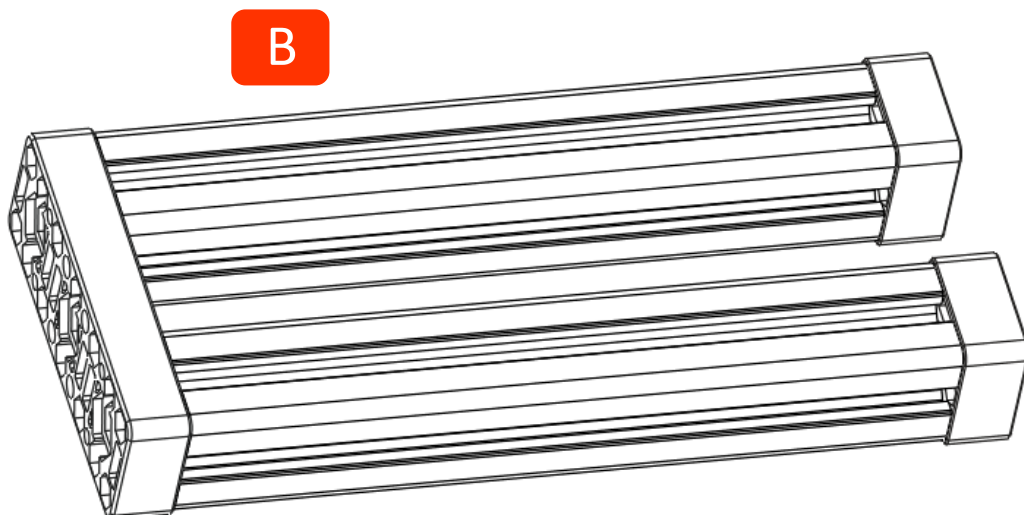
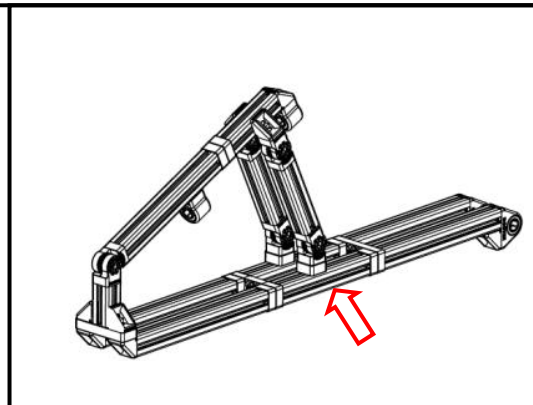
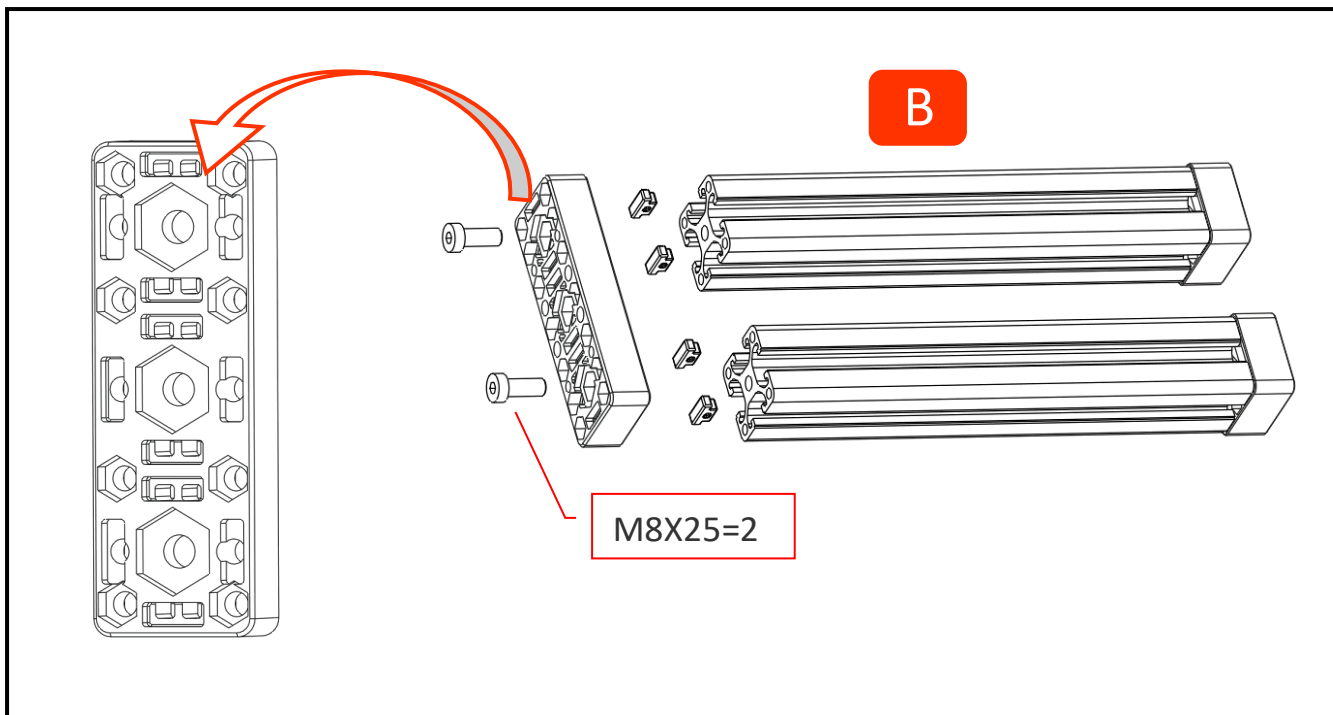

3

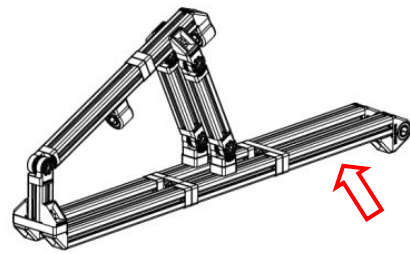

A

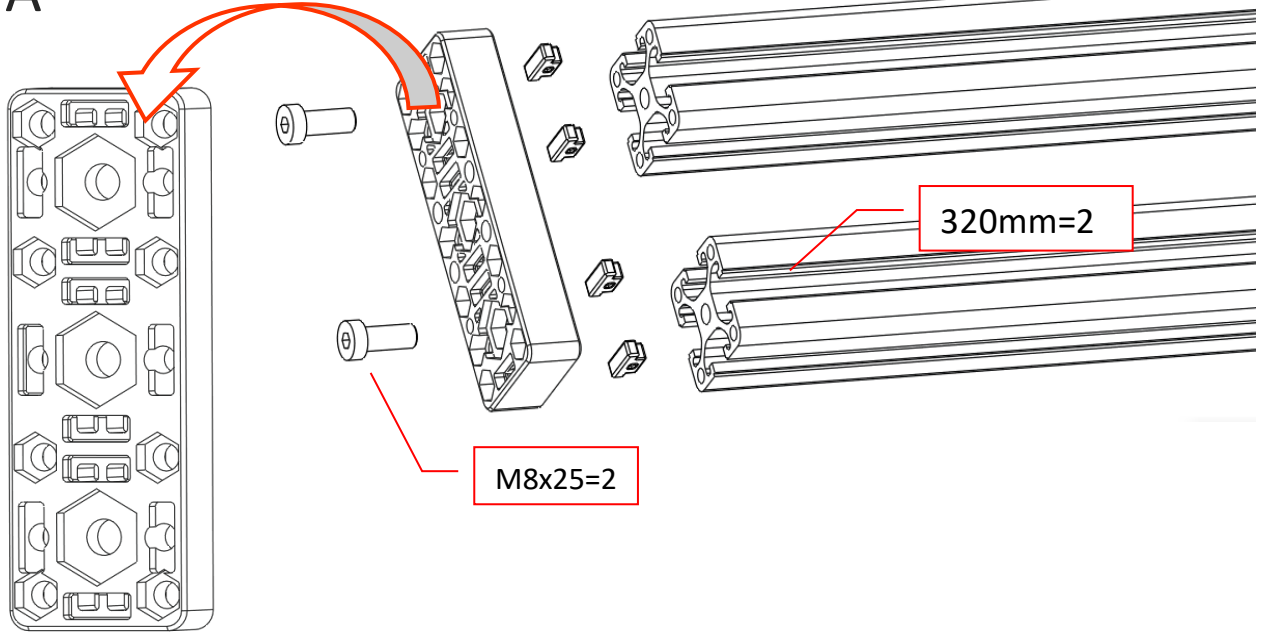

Privijte vijake s polno silo, da bi  
preprečili odvijanje.

C

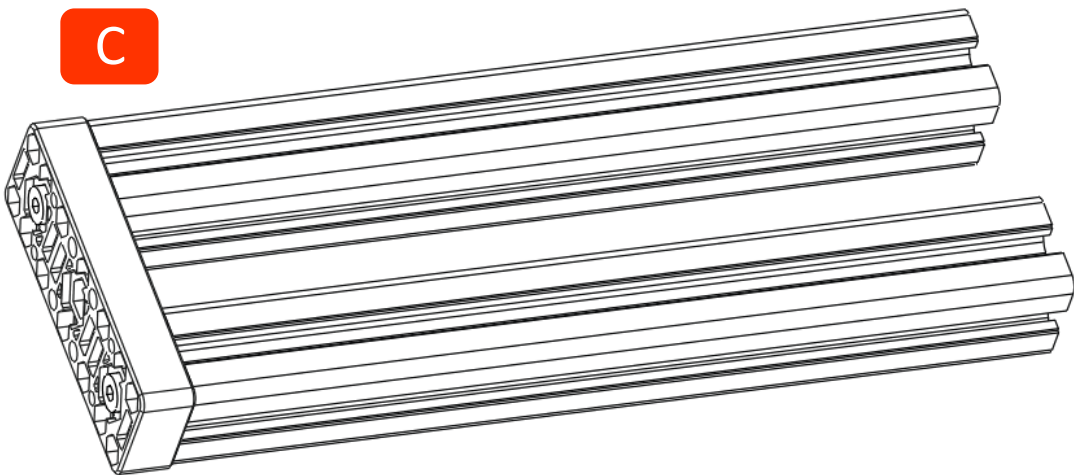

4

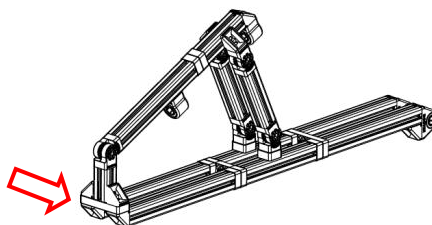

A

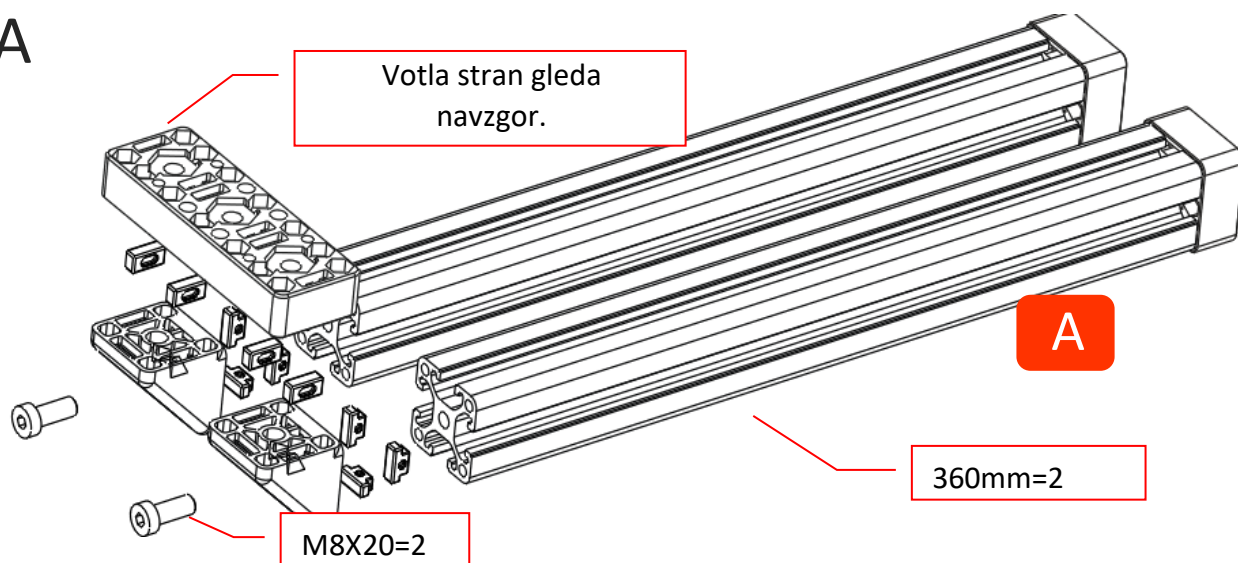

B

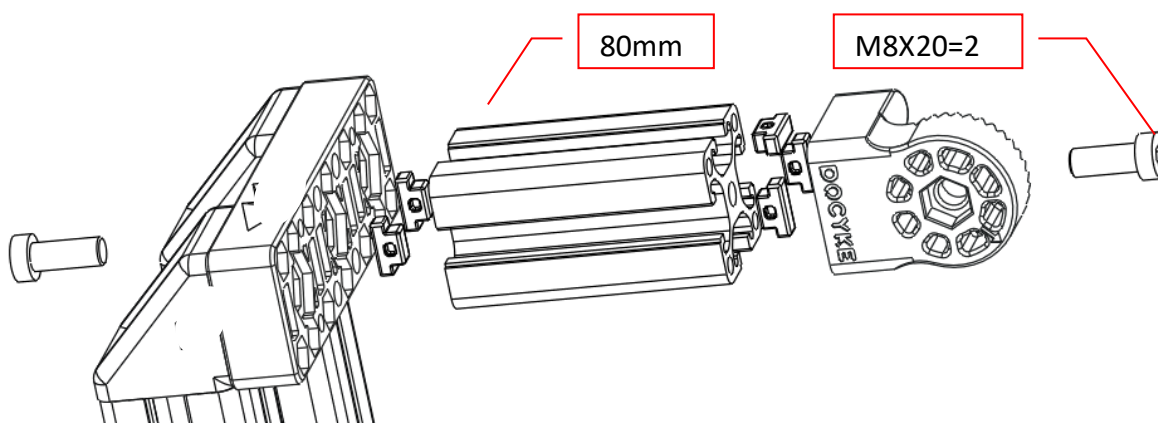

C

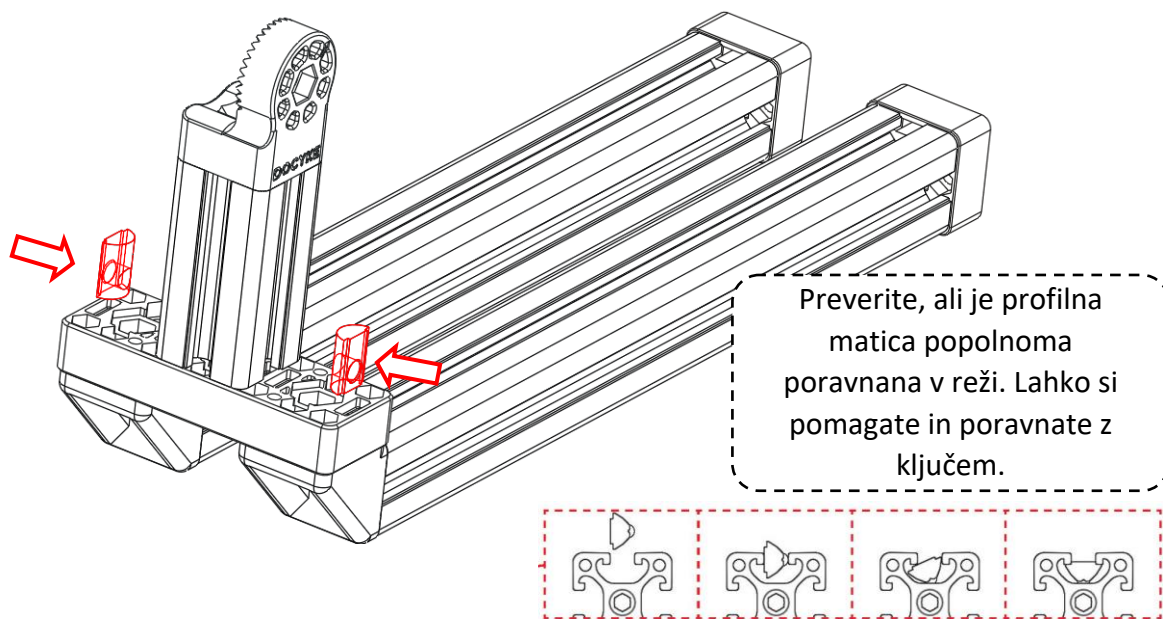



D

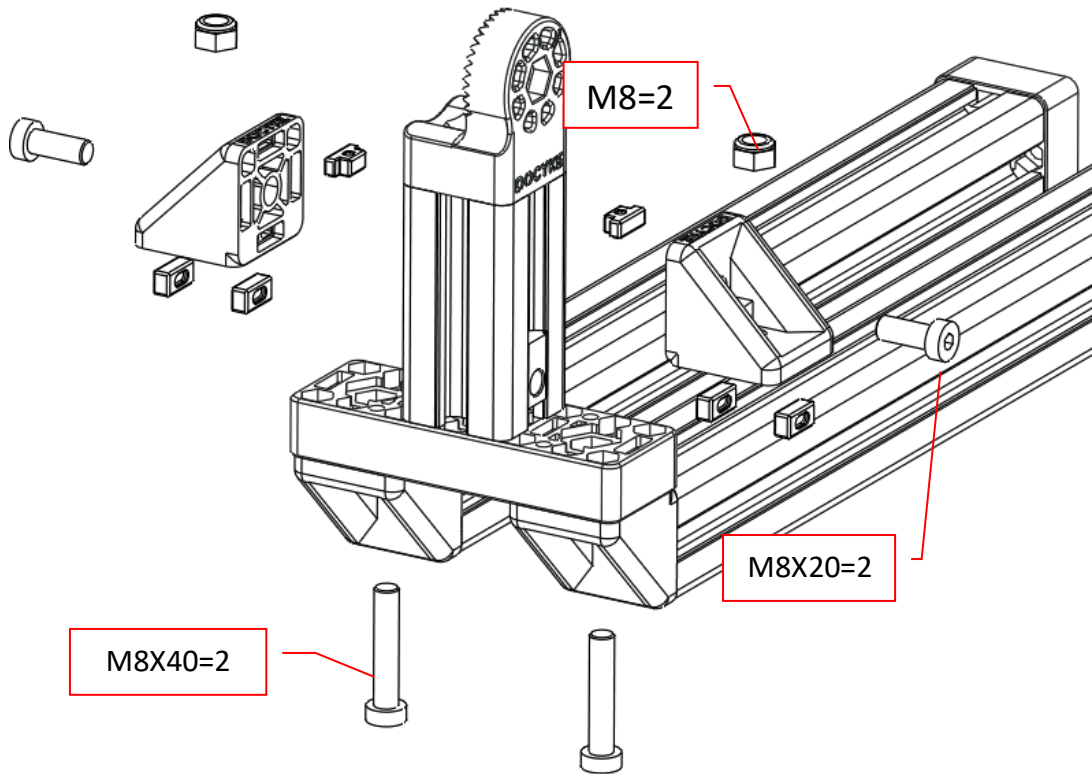

A

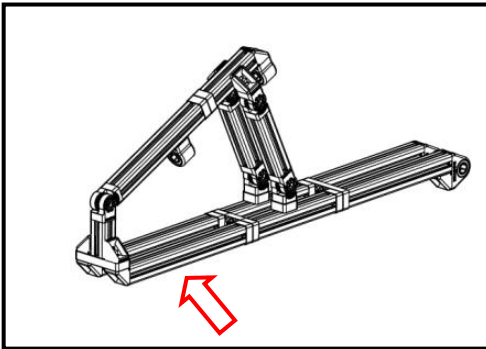
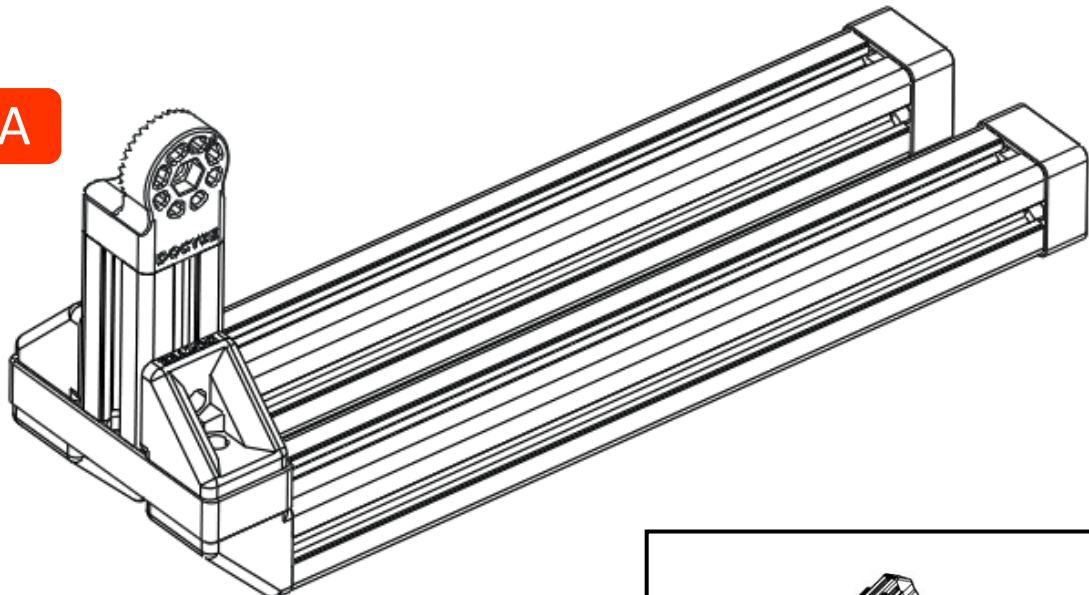

5

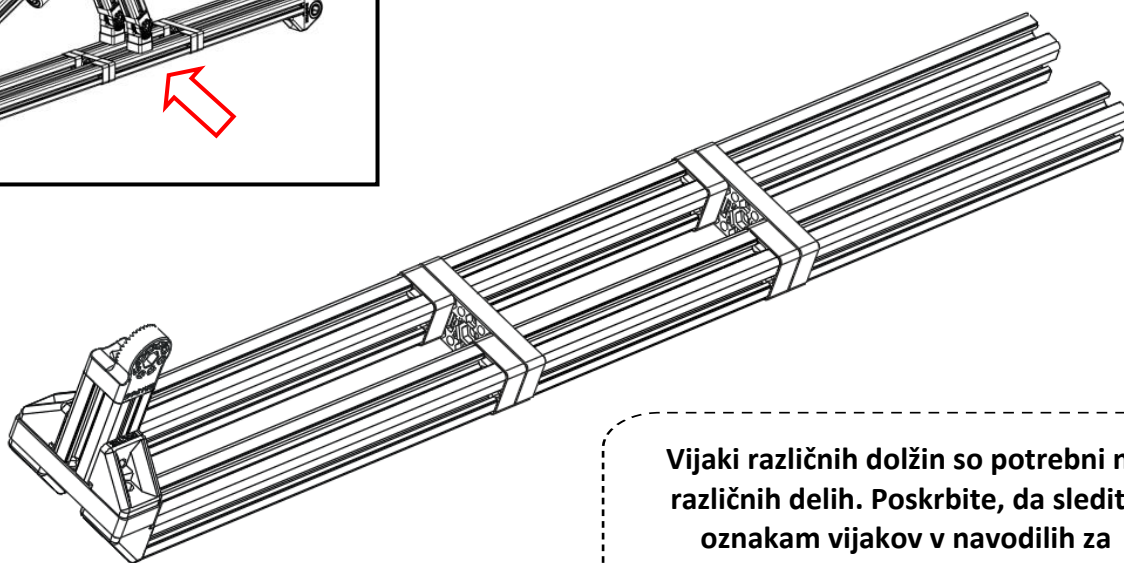
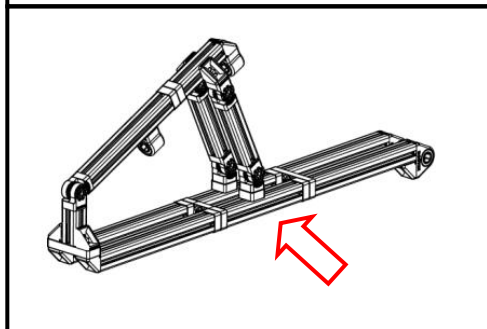
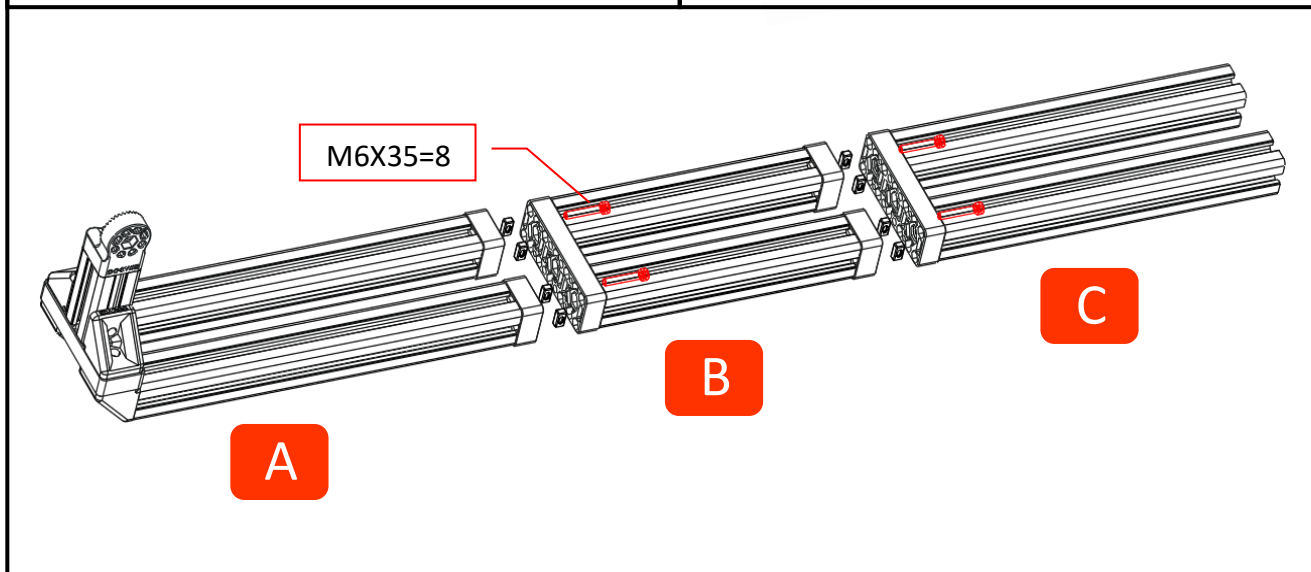
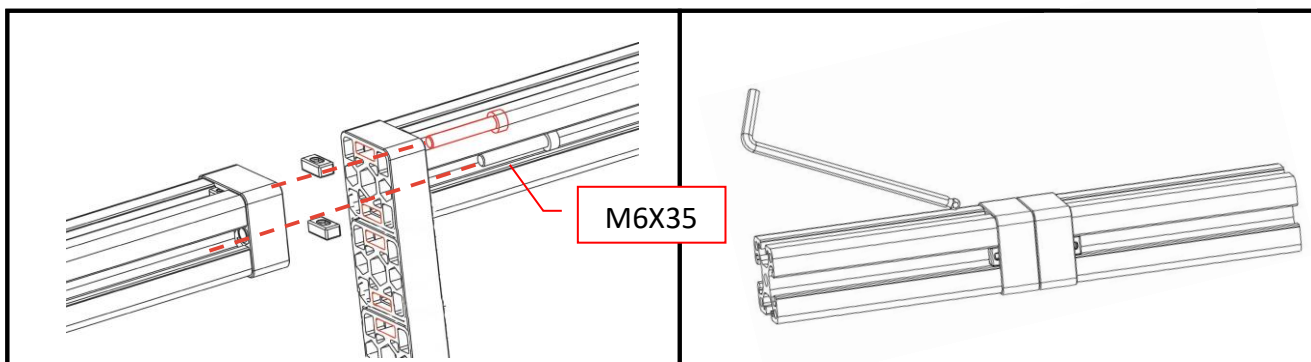

Vijaki različnih dolžin so potrebni na različnih delih. Poskrbite, da sledite oznakam vijakov v navodilih za sestavljanje.

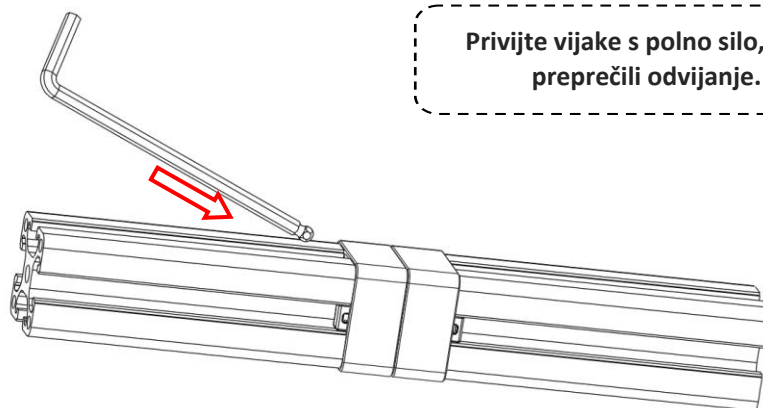
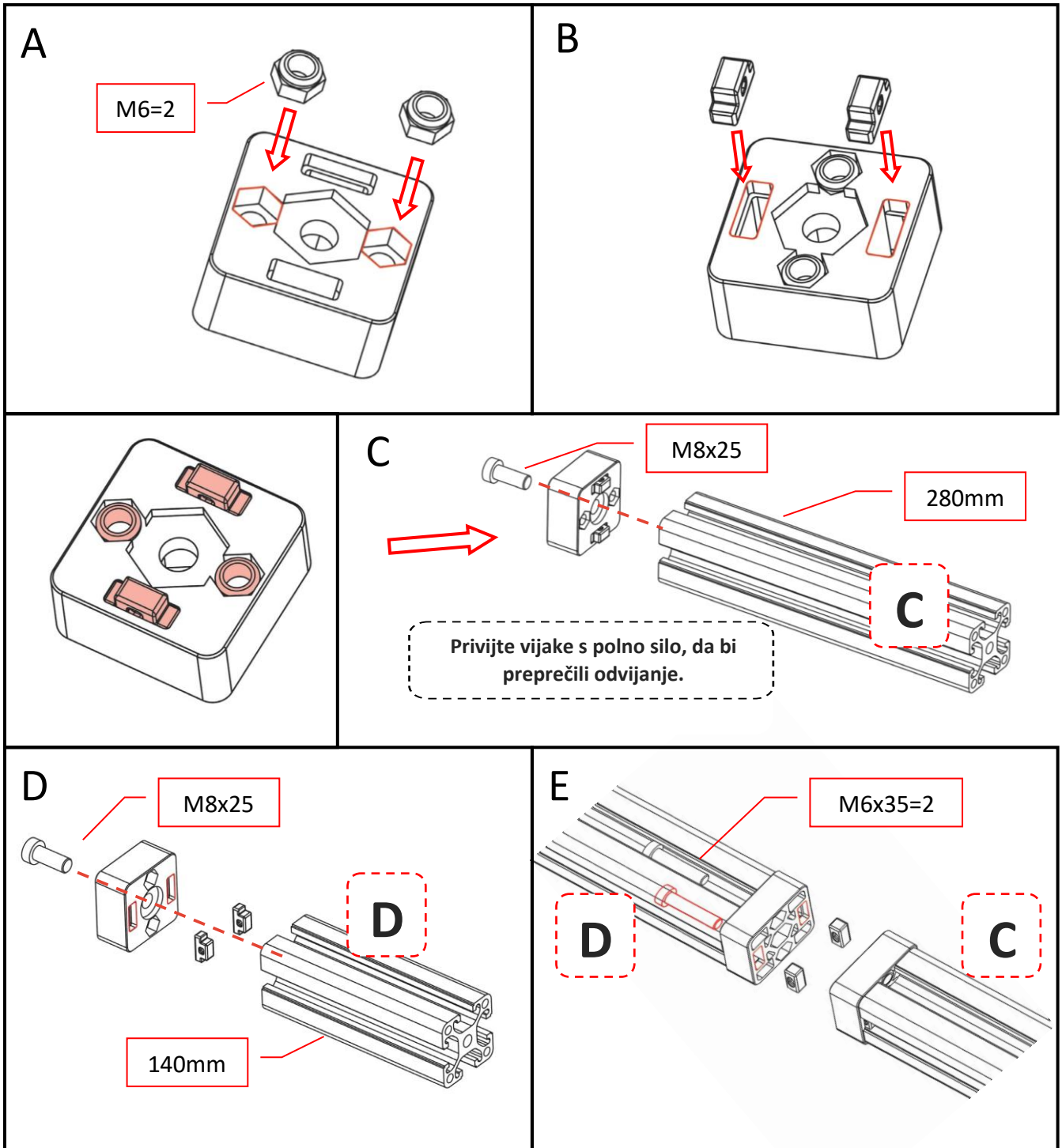



7

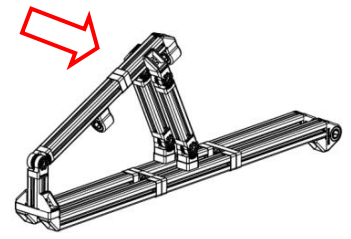
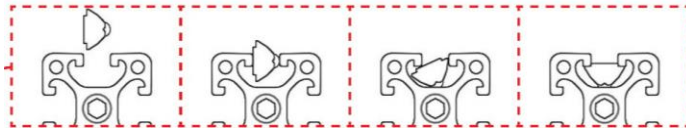

A

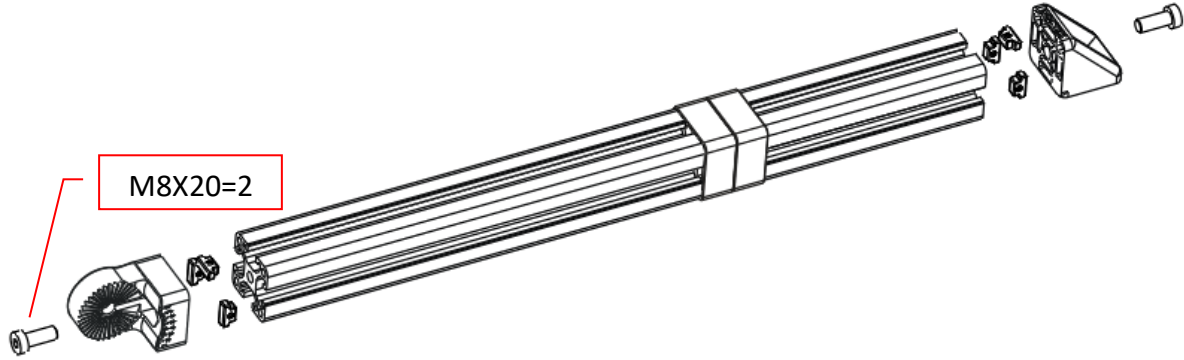

B

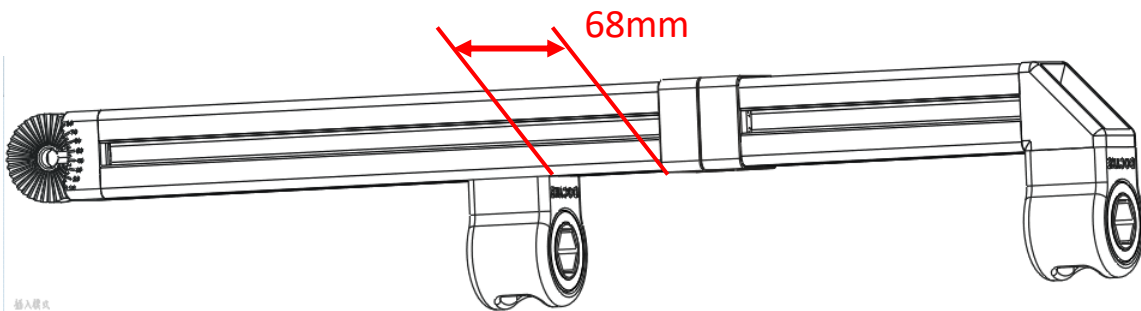
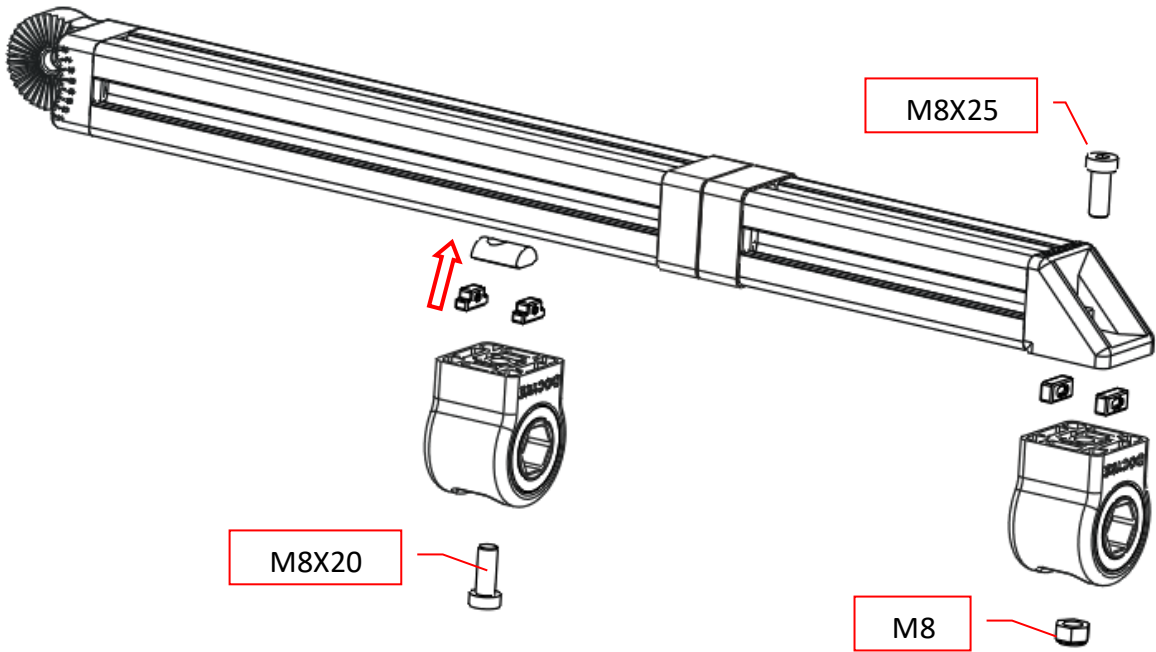

插入螺母

8

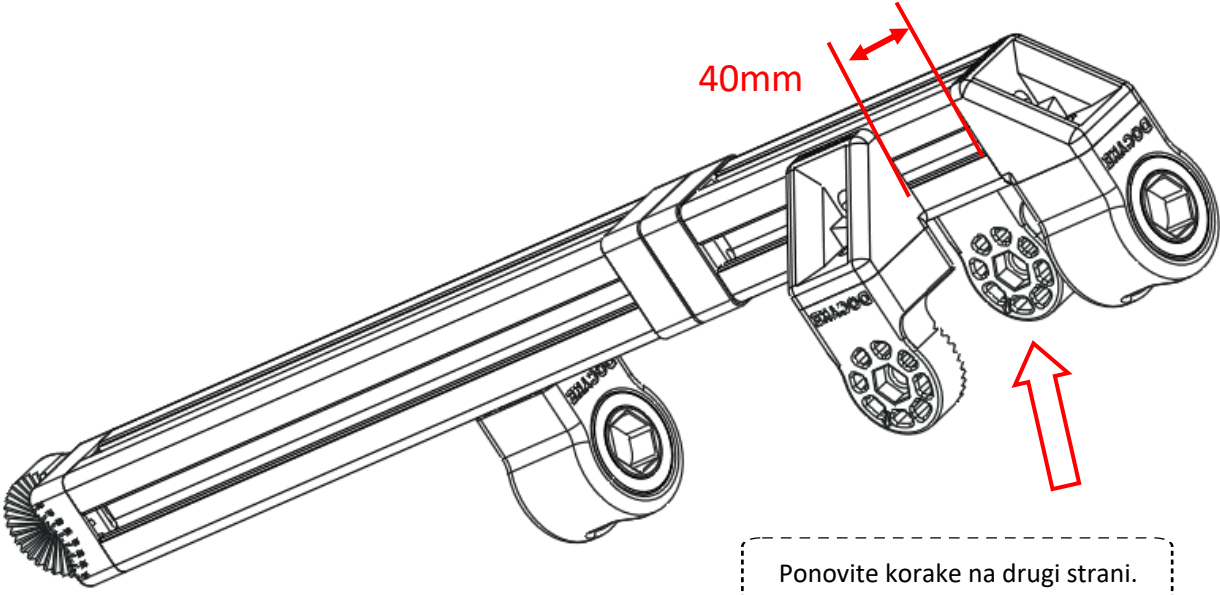
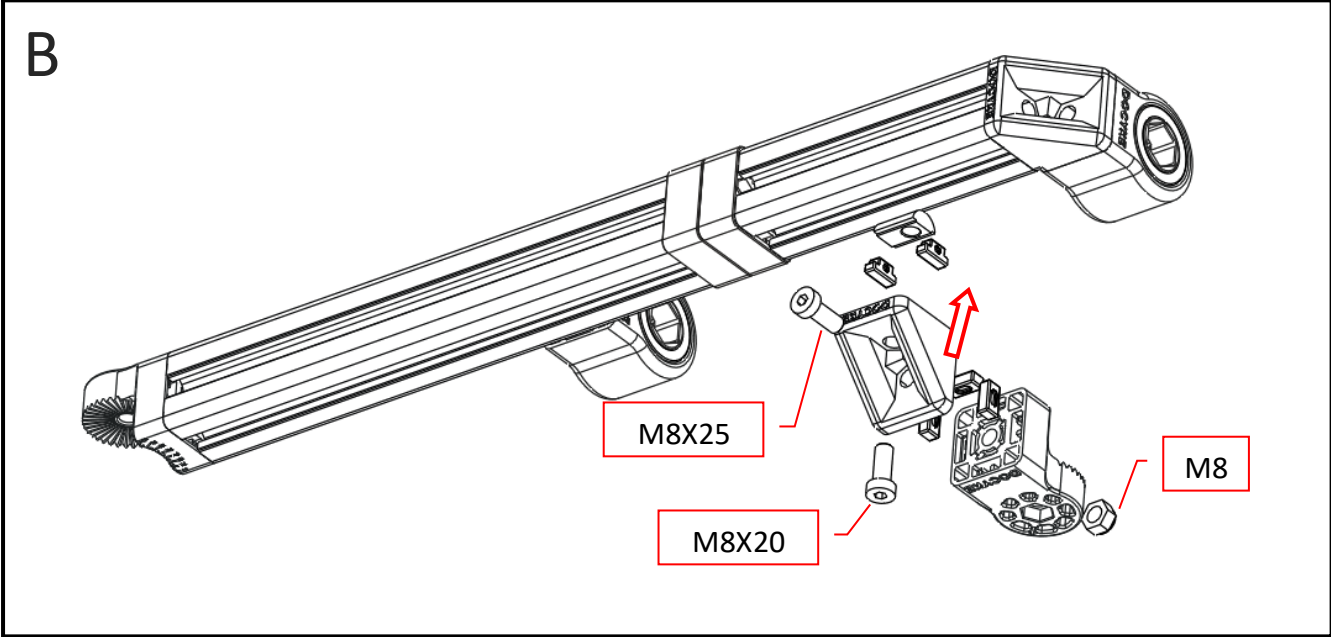
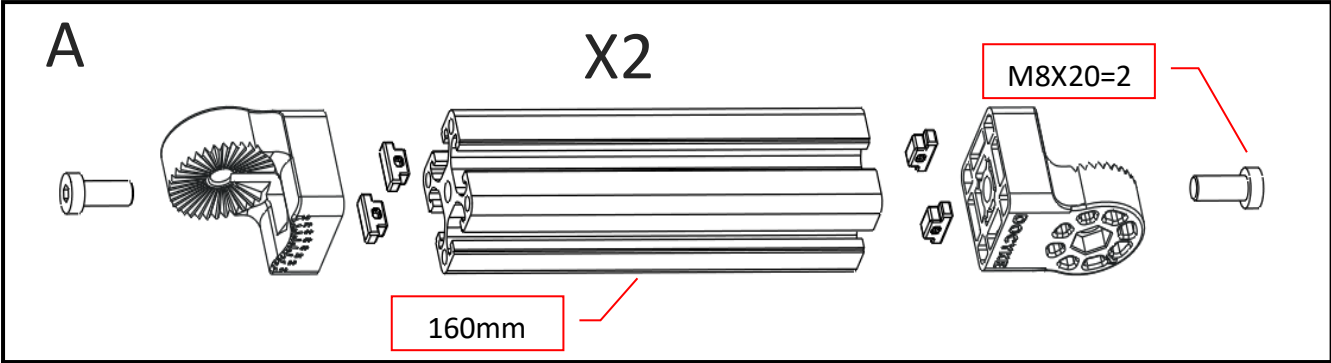
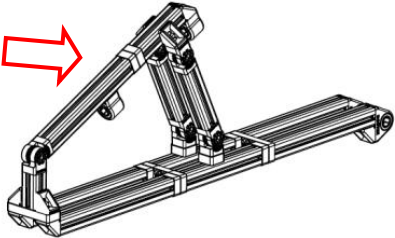

9

Izberite pravilen ozobljen disk.

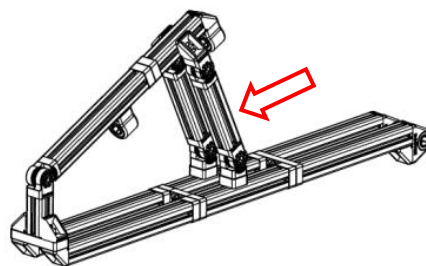

A

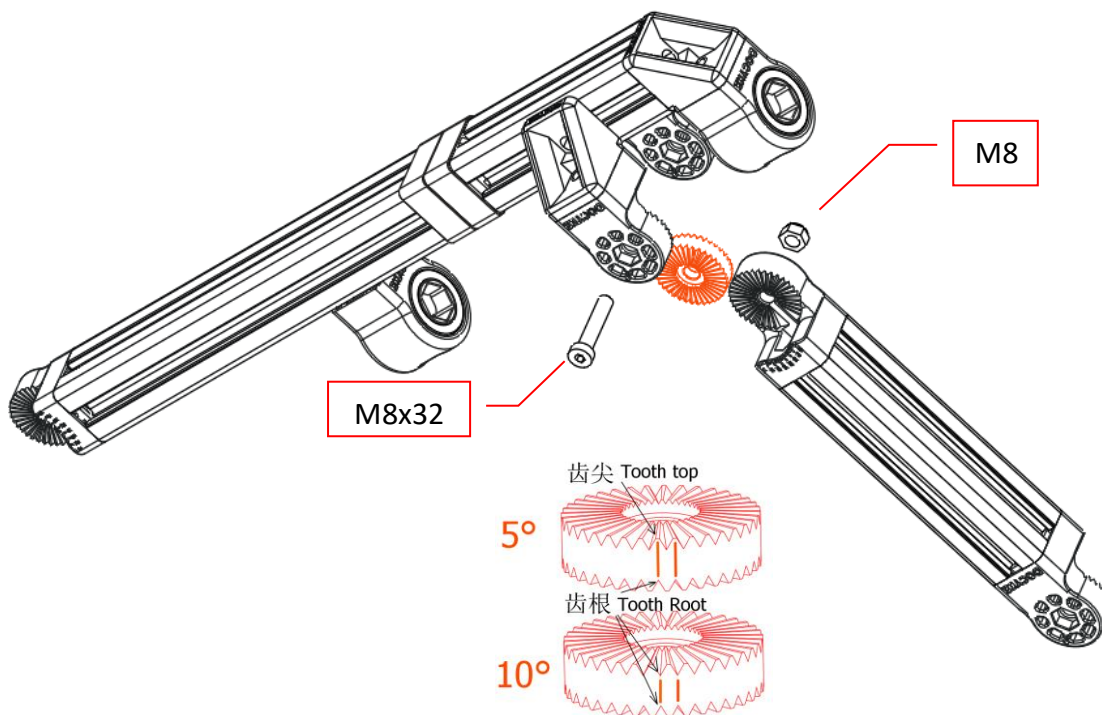

Obstajata dve vrsti ozobljenih diskov.

Eno vrsto diskov lahko namestite v 5° (stopinjskih) korakih: (5°, 15°, 25° itd). Drugo pa lahko namestite v 10° (stopinjskih) korakih: (10°, 20°, 30° itd).

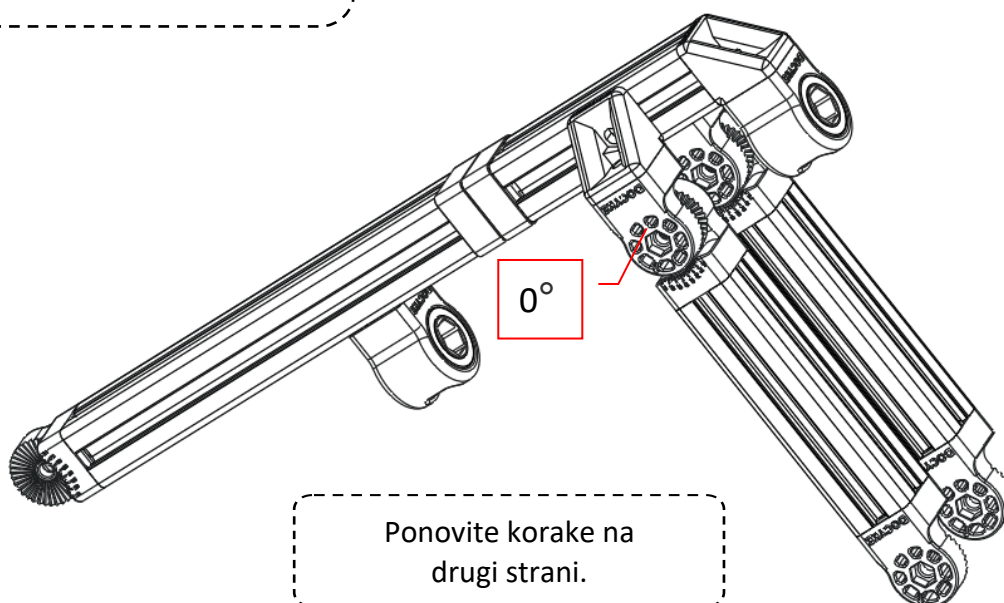

Ponovite korake na drugi strani.

10

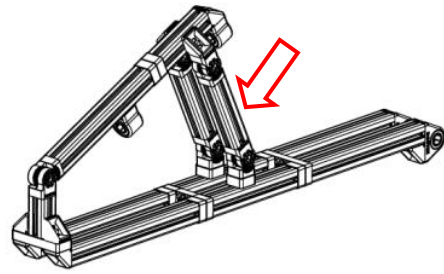

A

M8X40-2

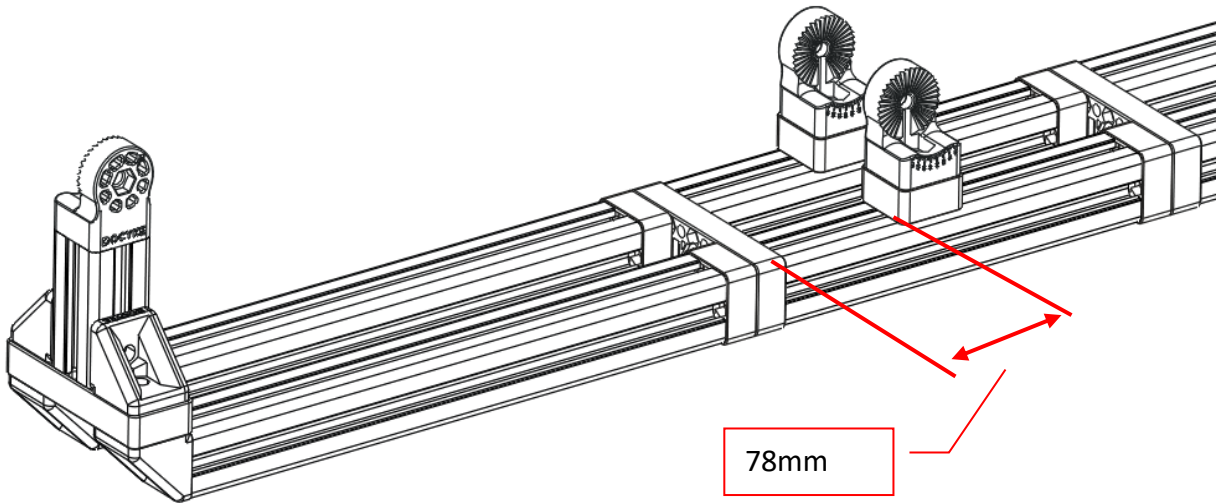
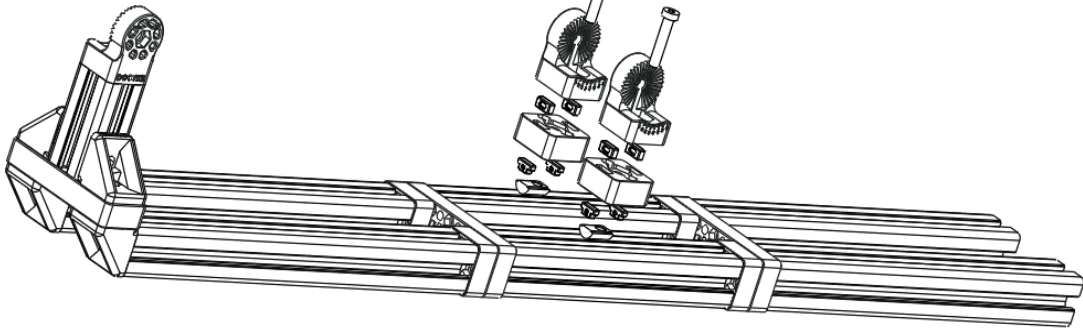



11

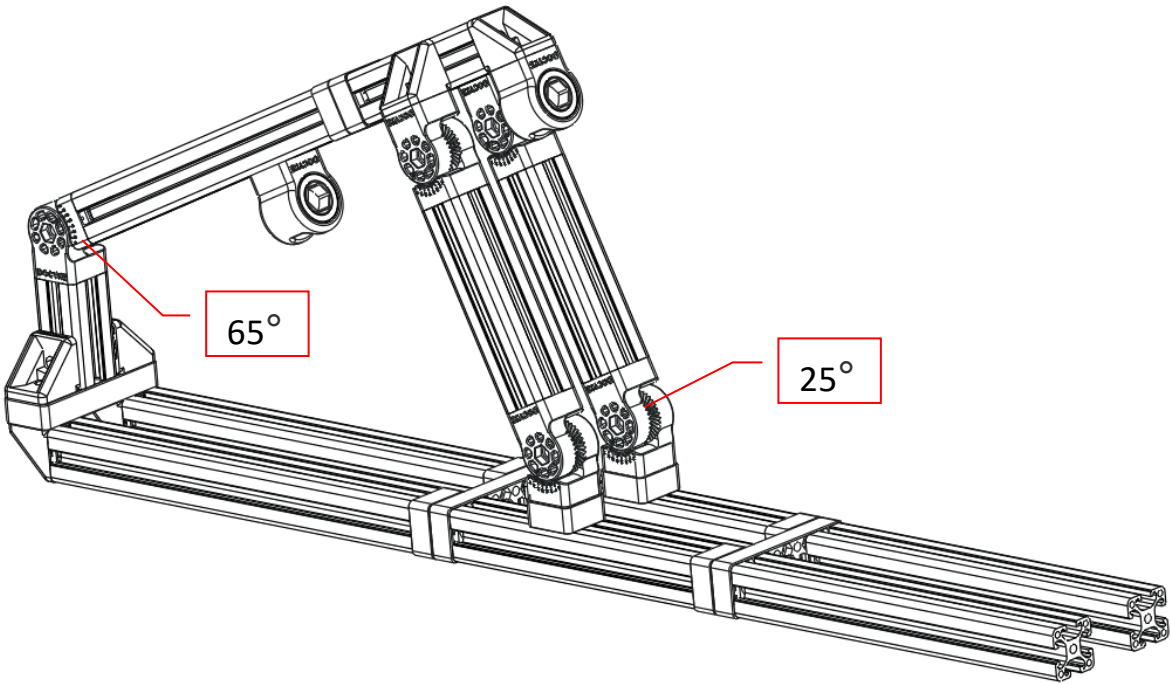
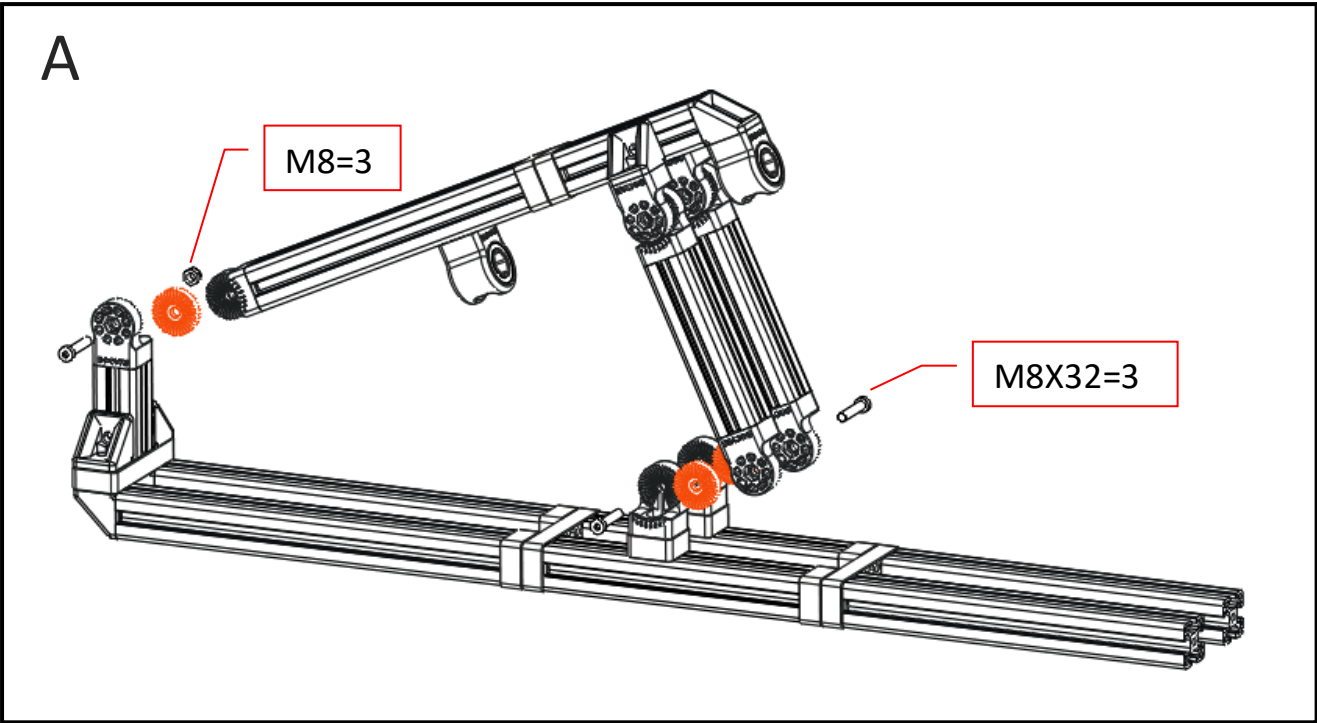
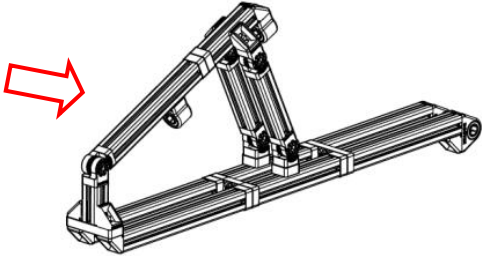

12

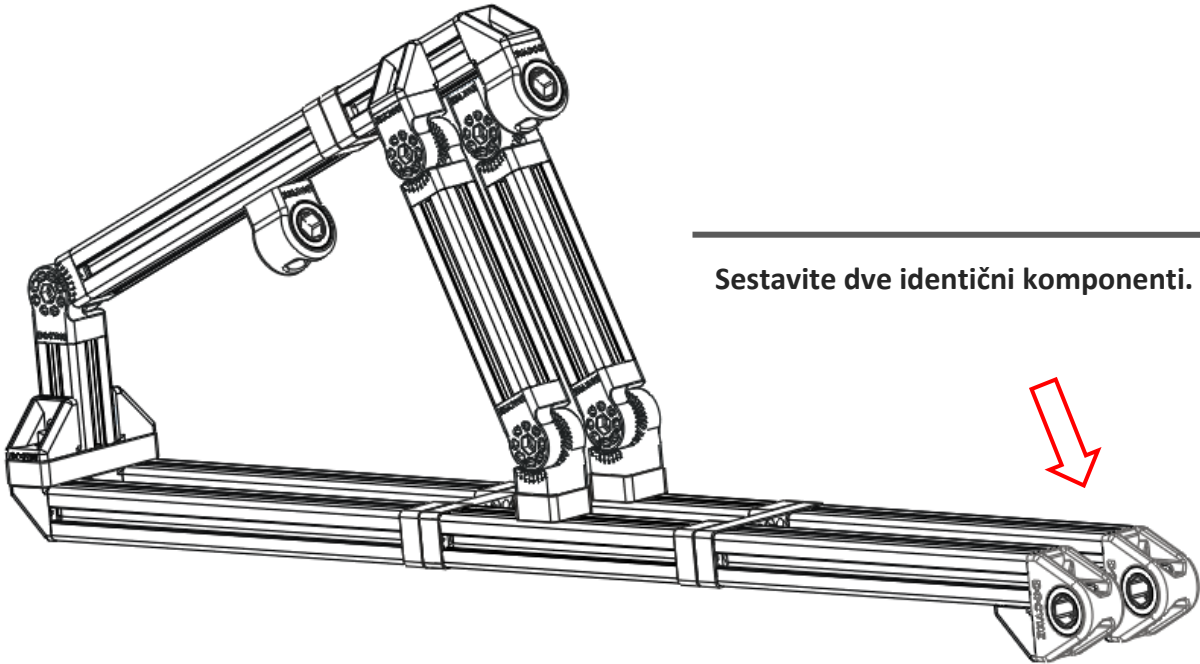
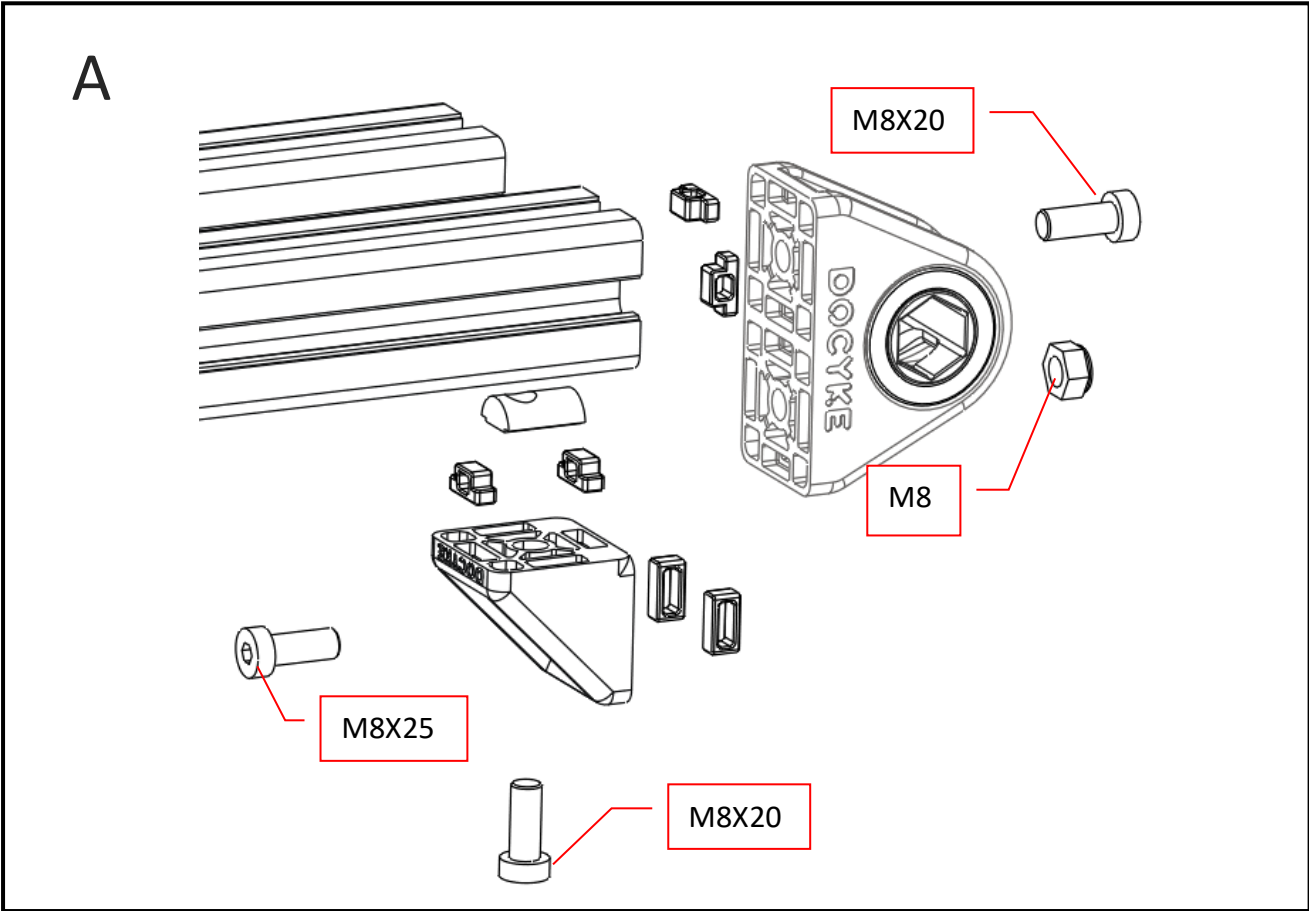
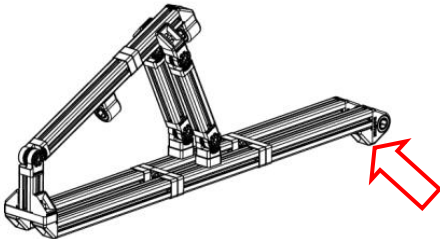

Sestavite dve identični komponenti.

13

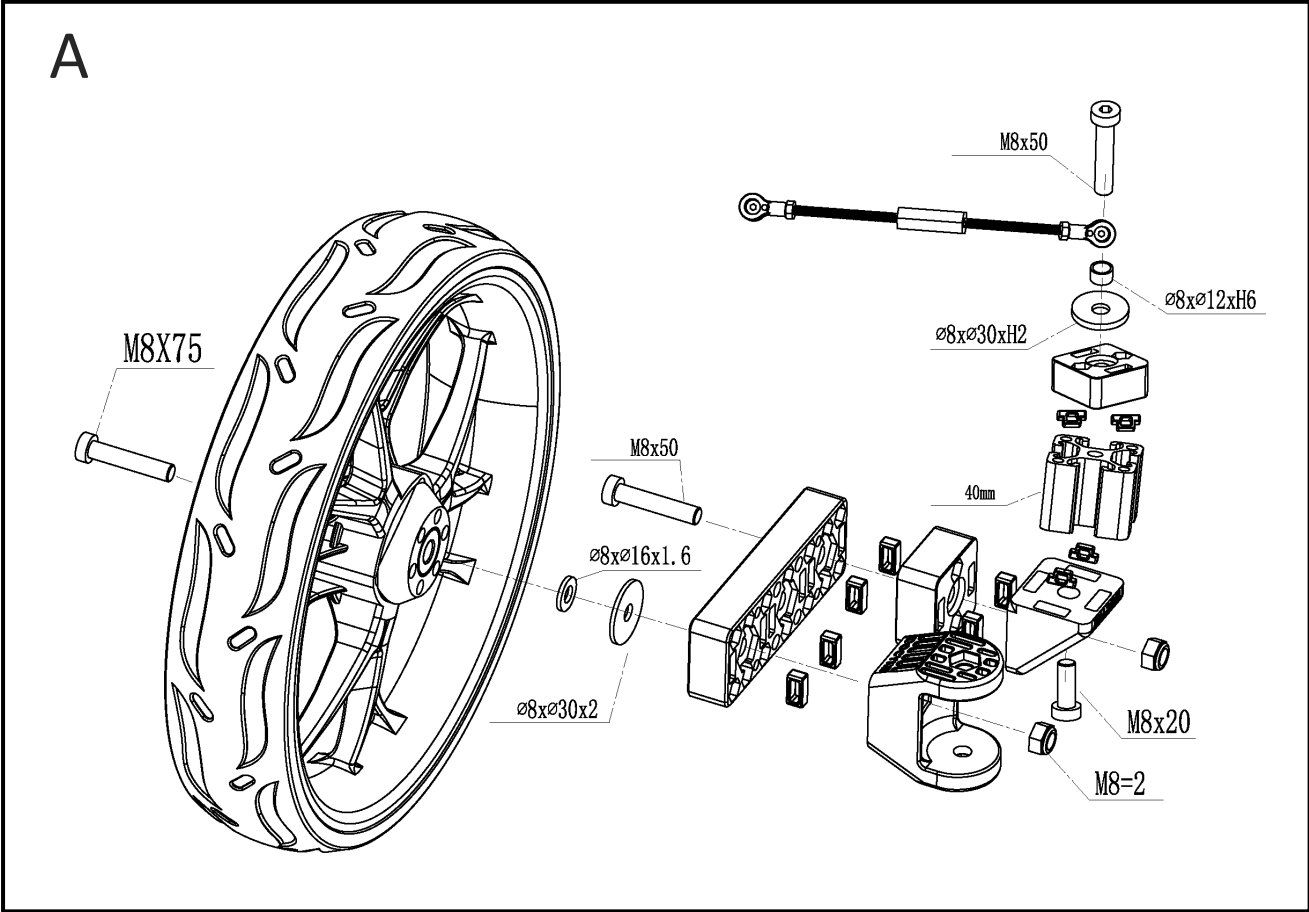
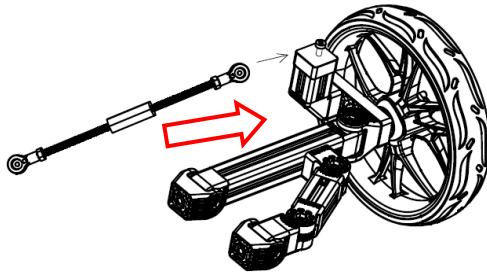

Sestavite dve identični komponenti.

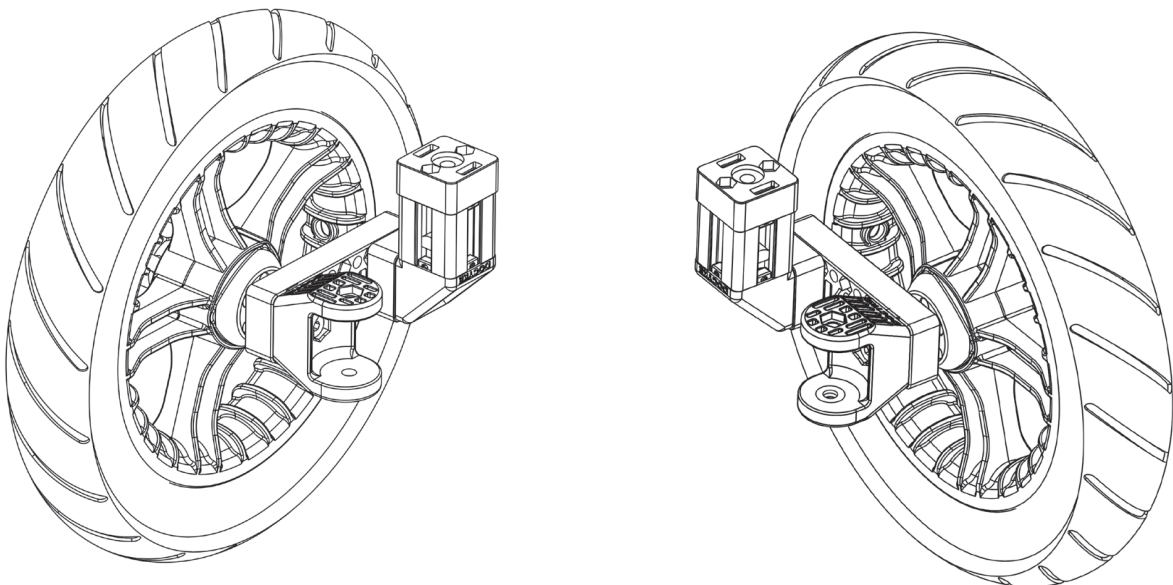

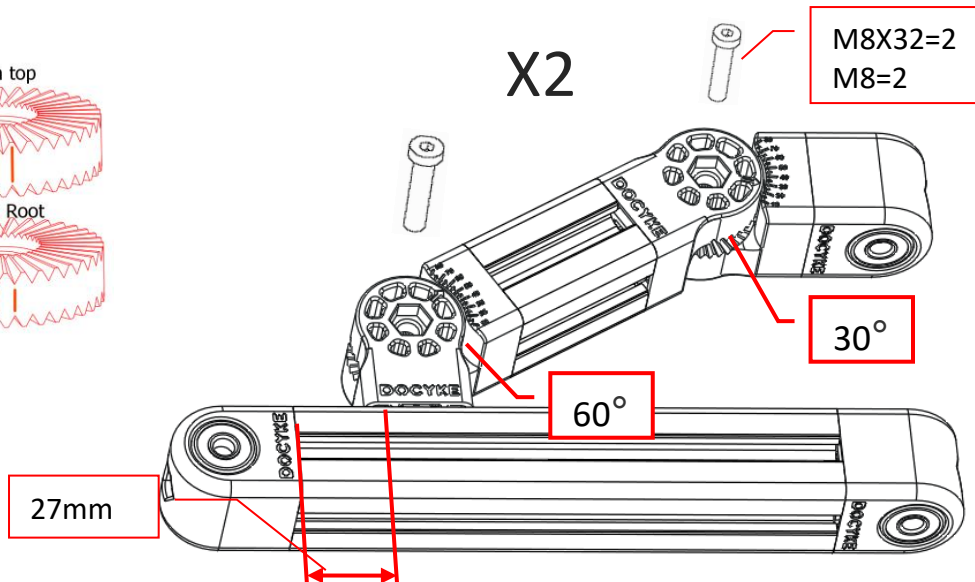
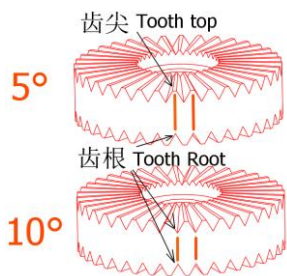
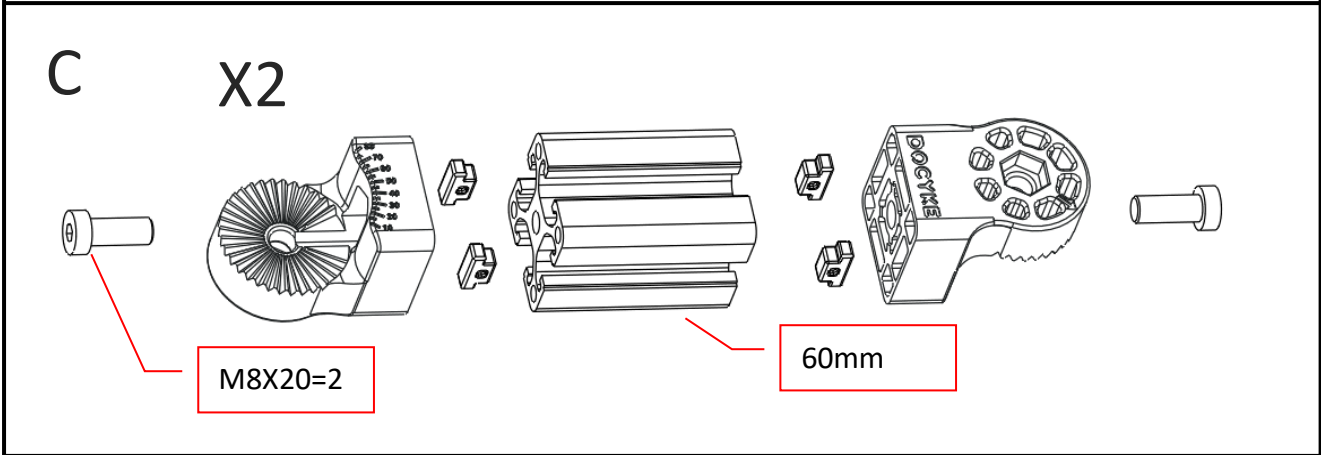
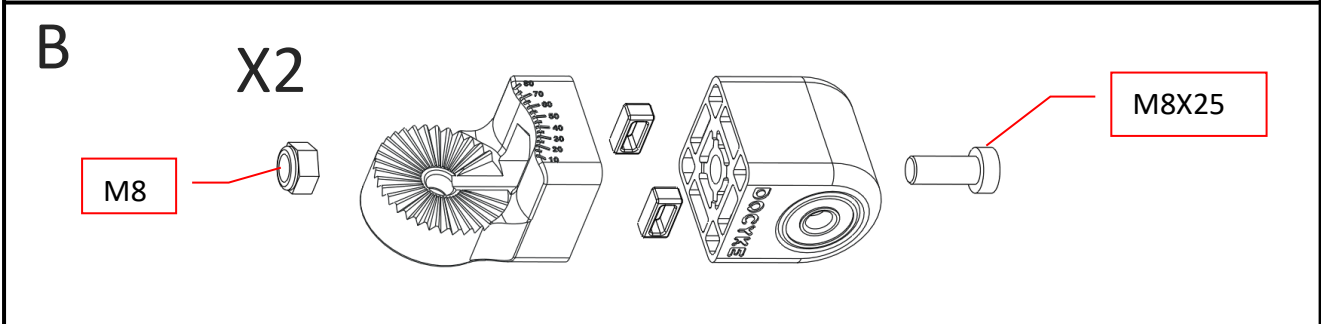
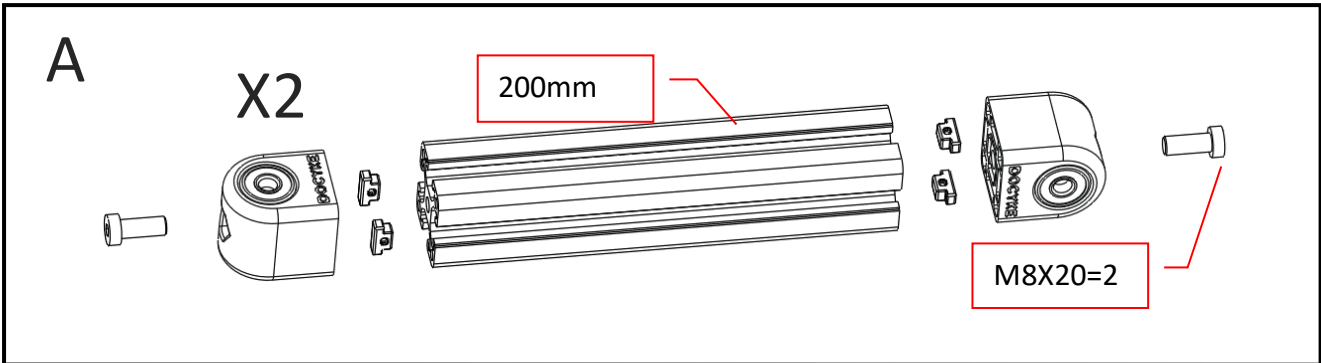
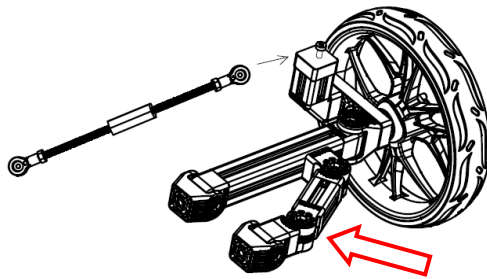



15

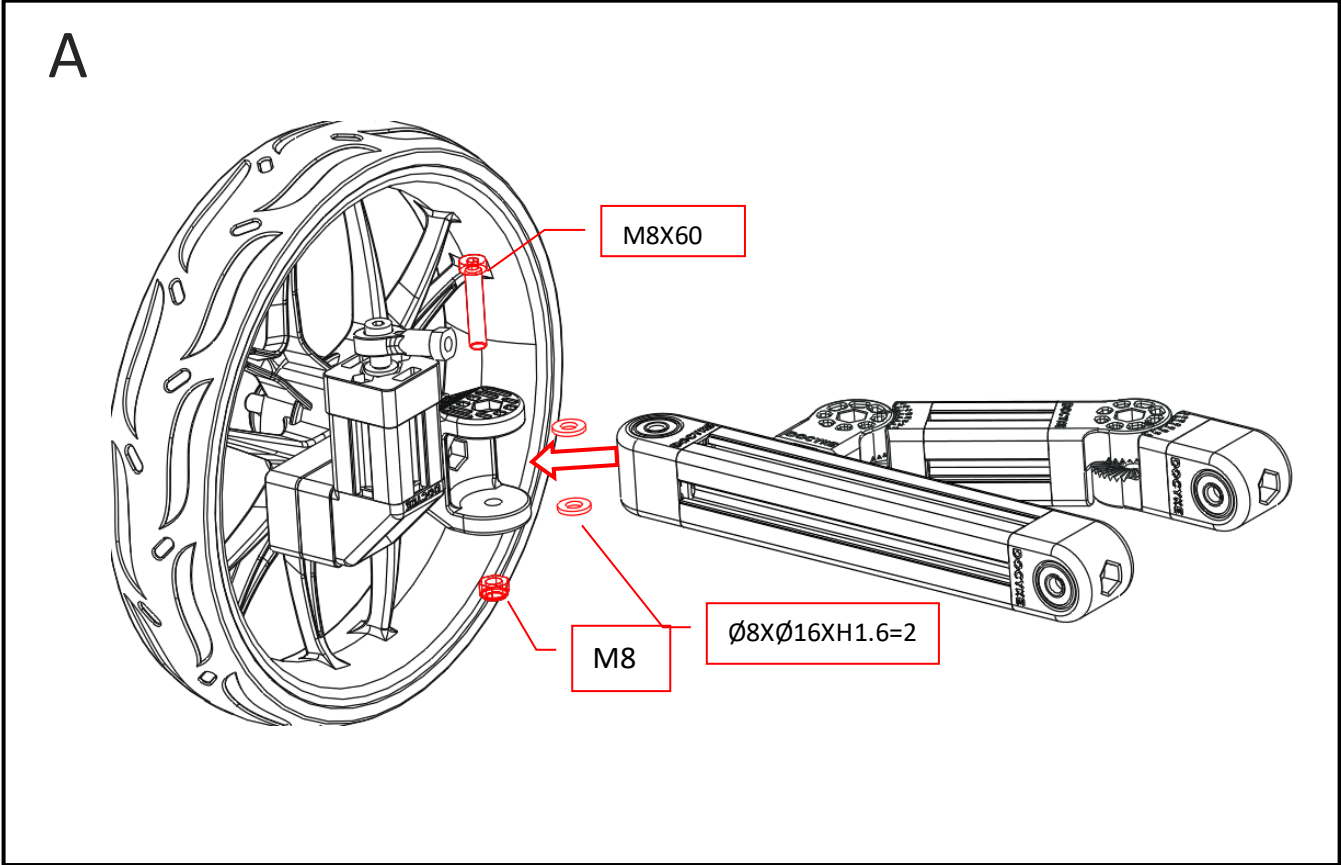
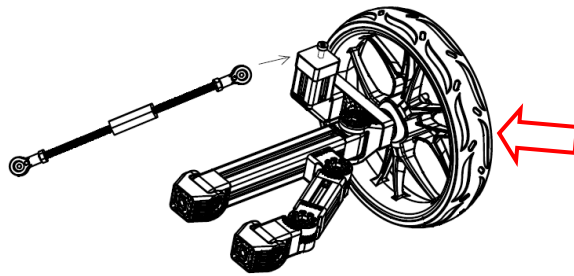

Sestavite levo in desno  
vzmetenje.

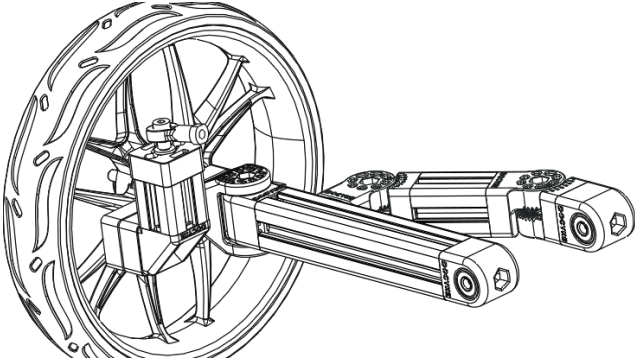

Left

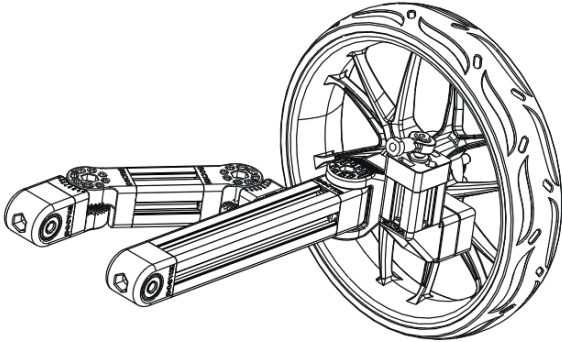

Right

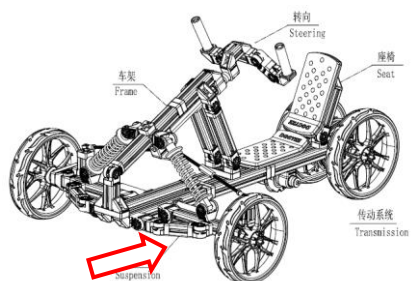

A

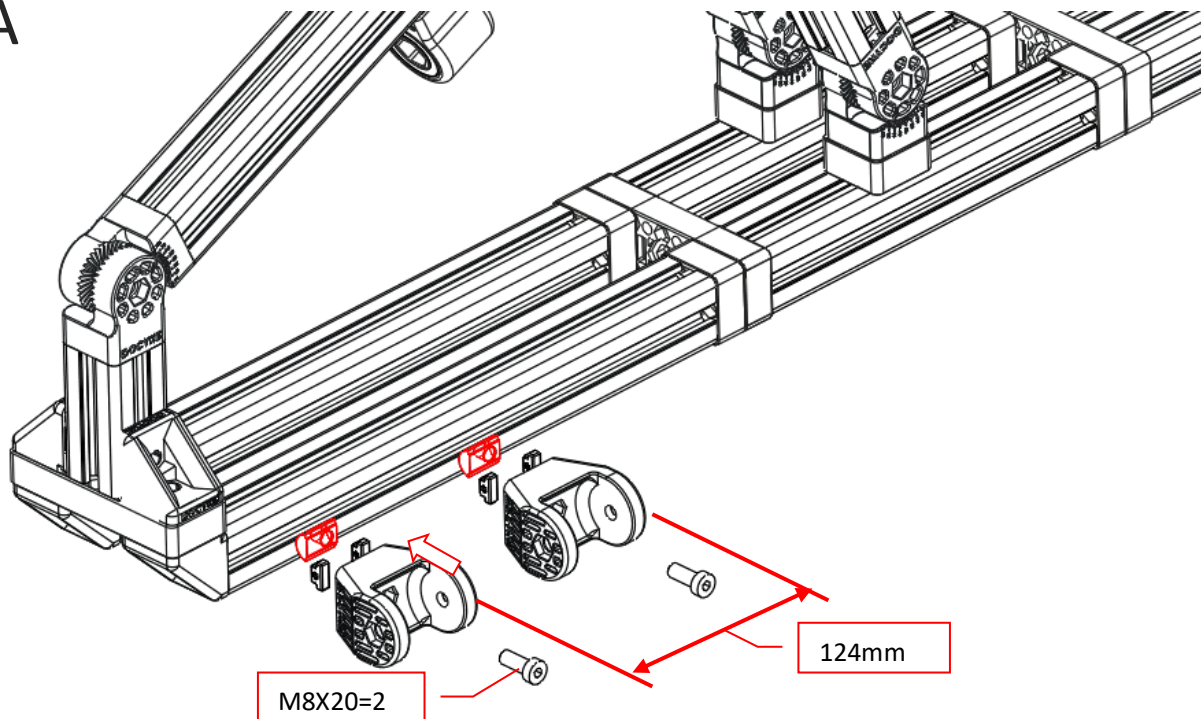

B

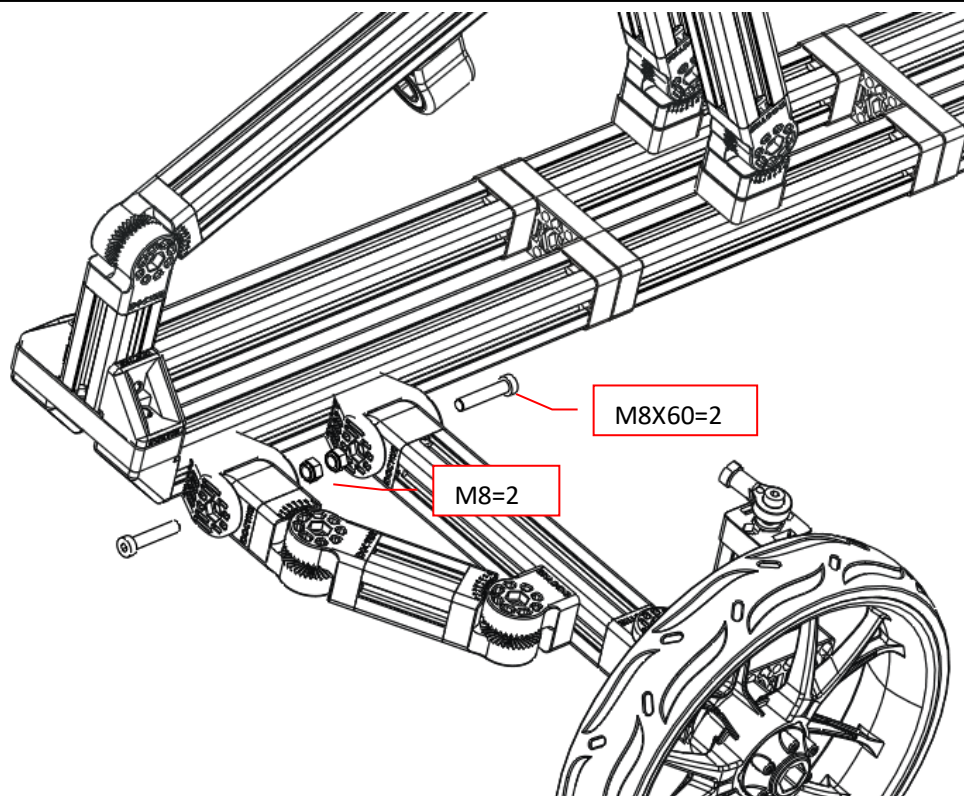

A

Sestavite levo in desno  
vzmetenje.

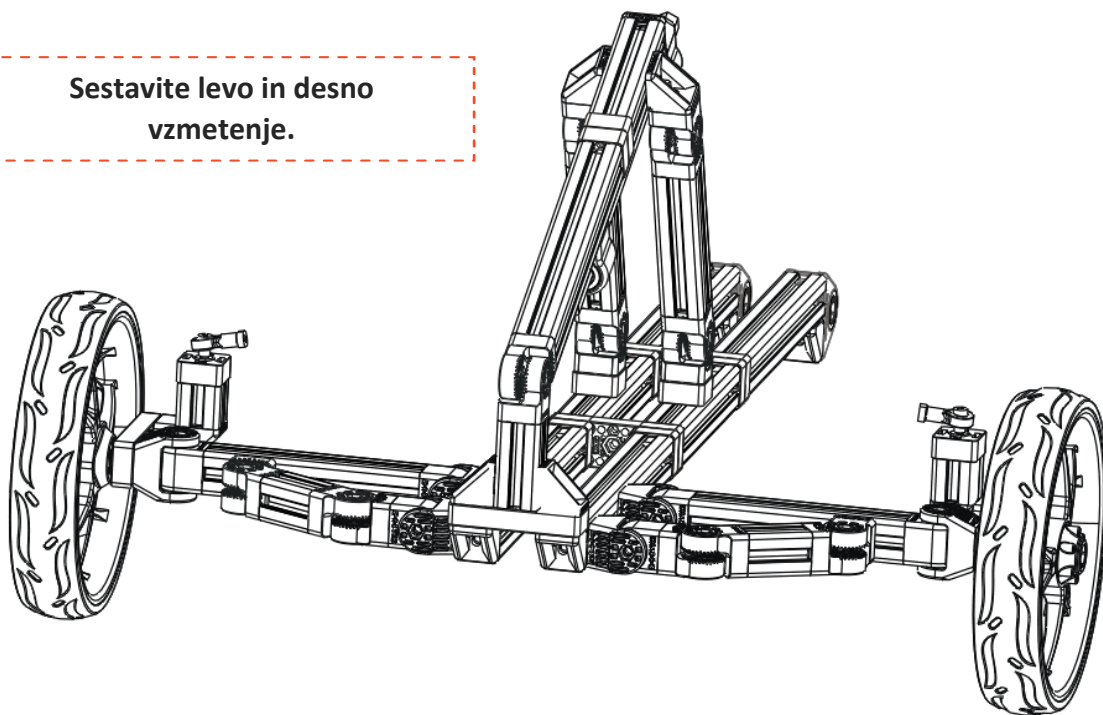

B

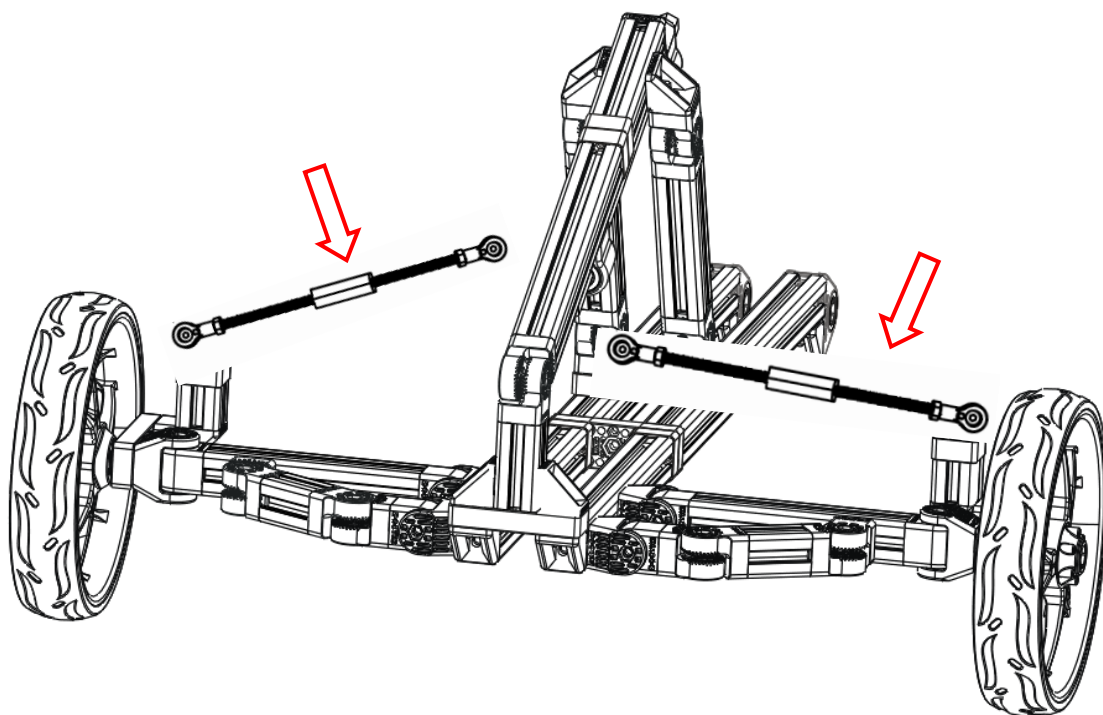



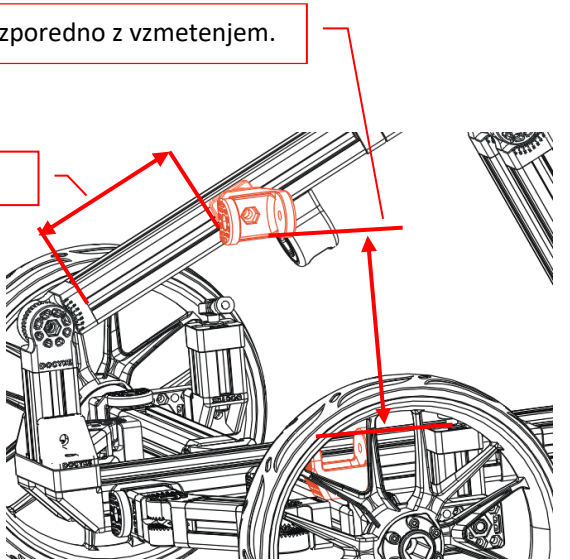
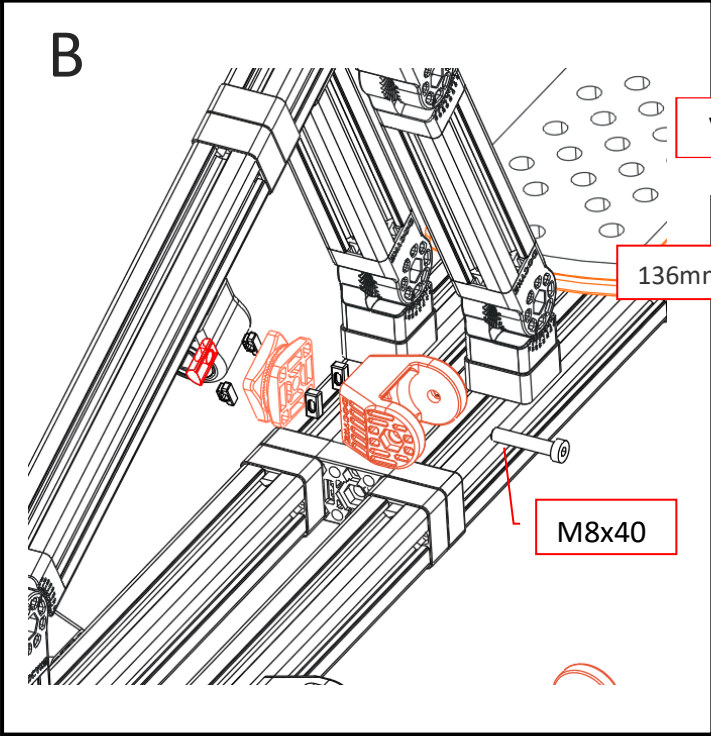
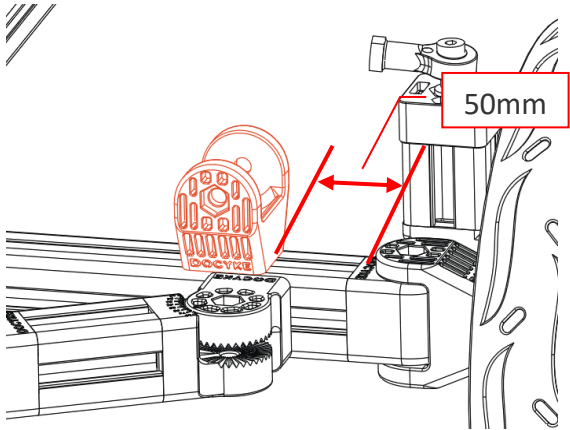
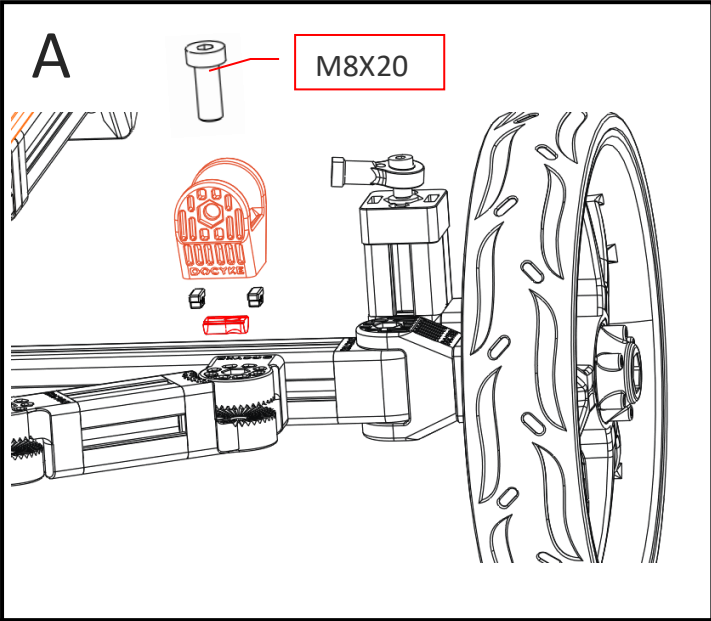
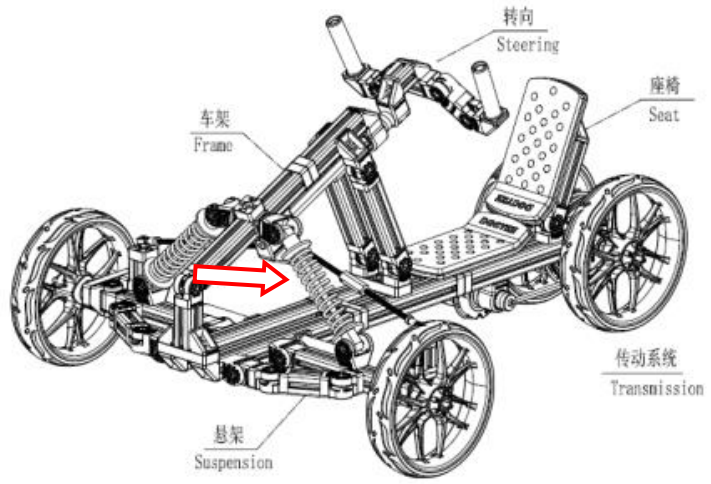

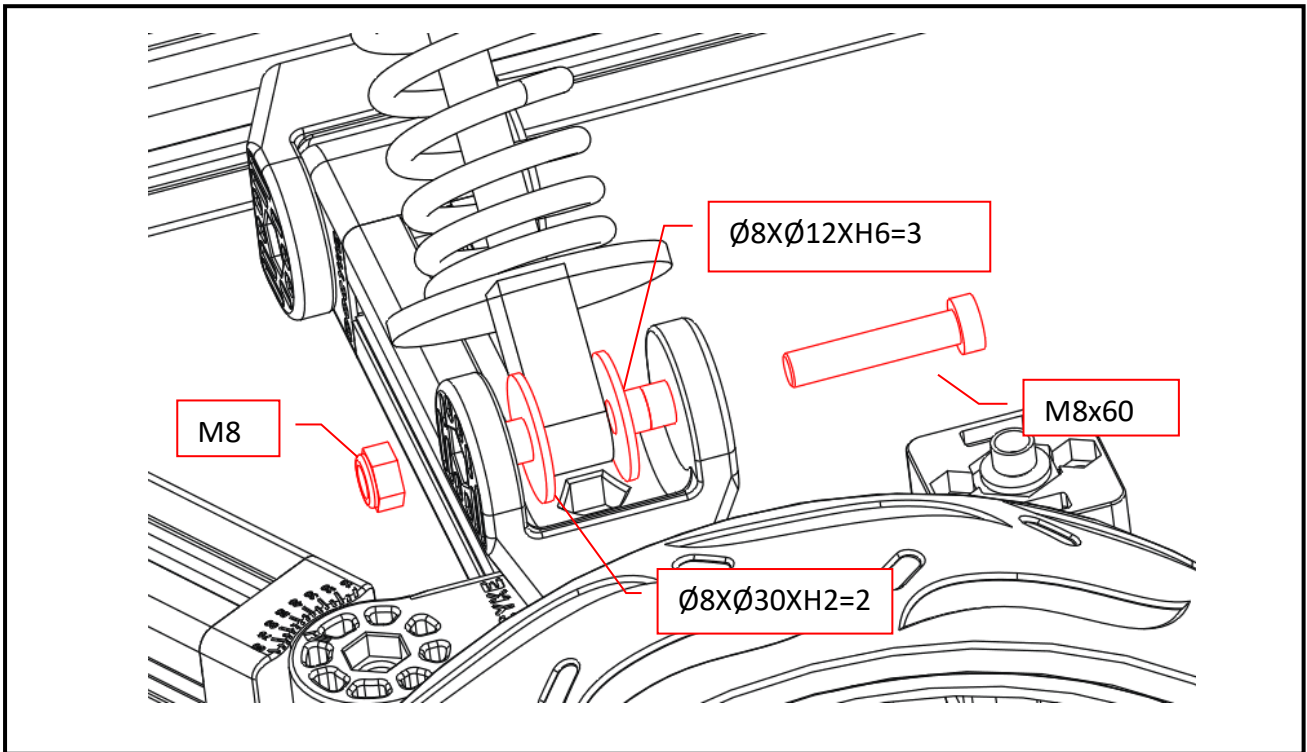

Ponovite te korake in sestavite drugo stran.

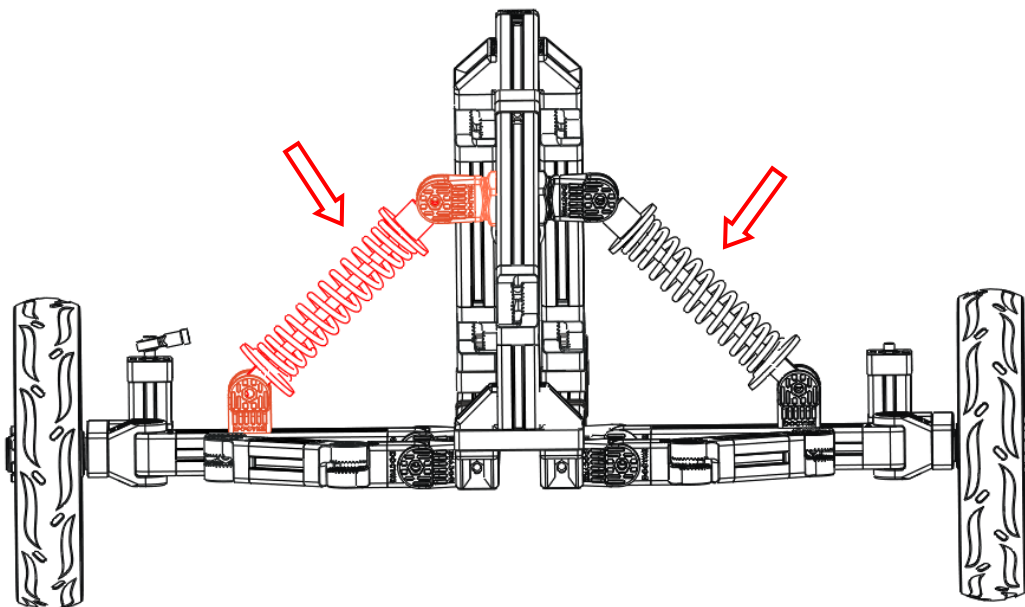

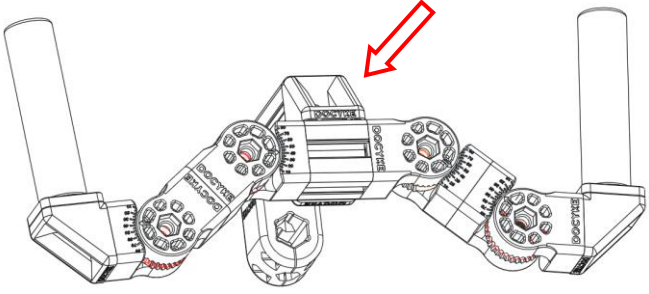

A

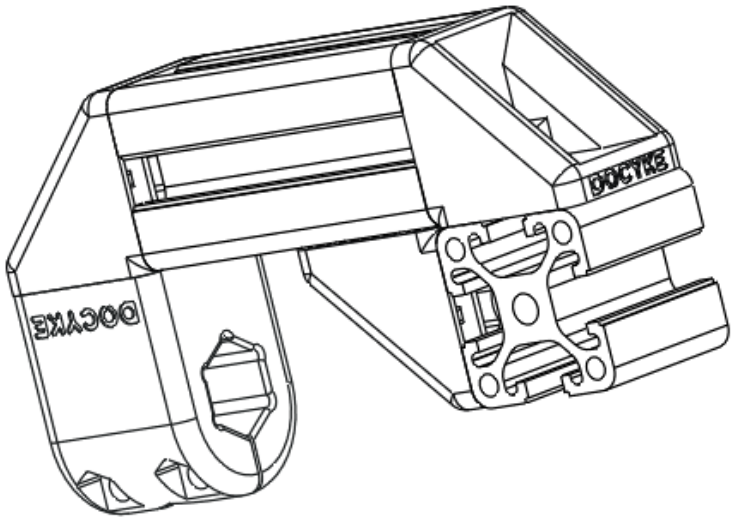
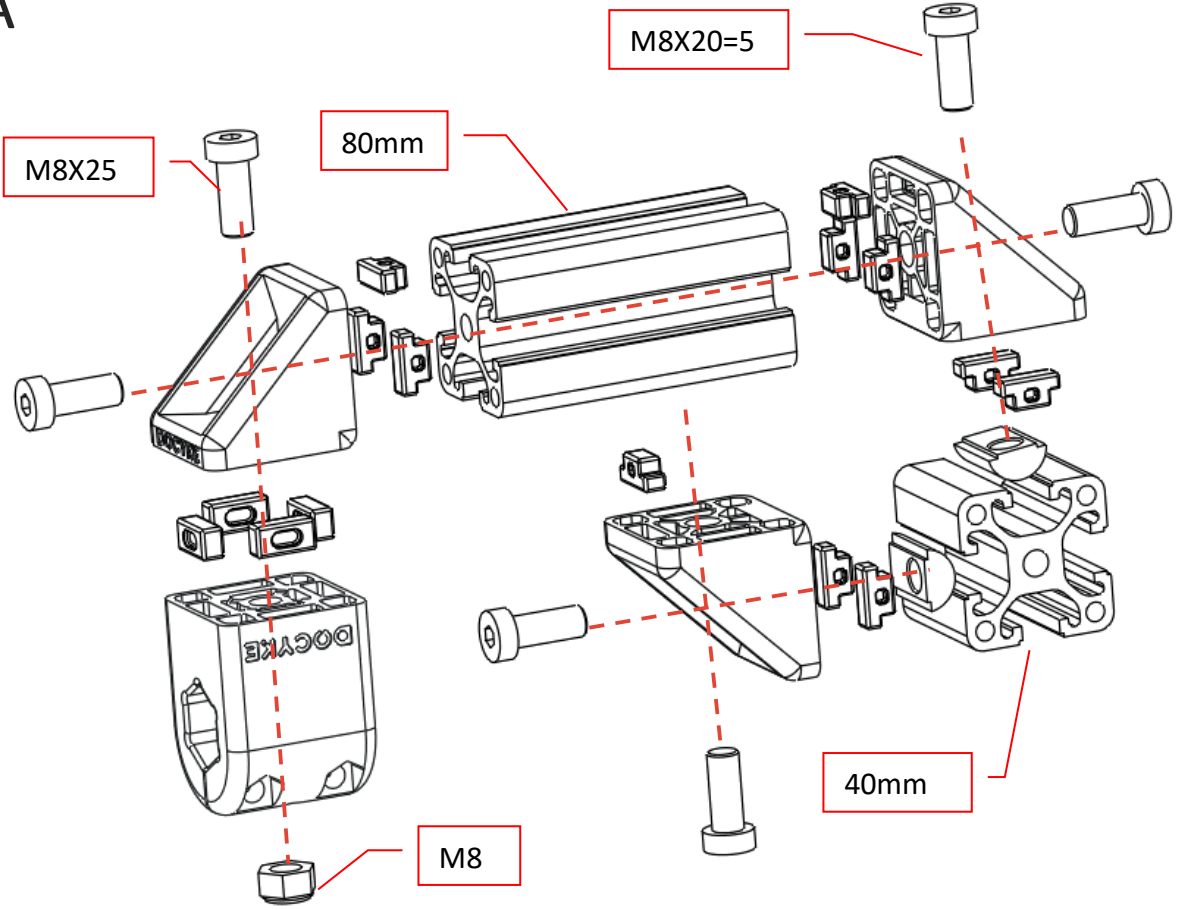

21

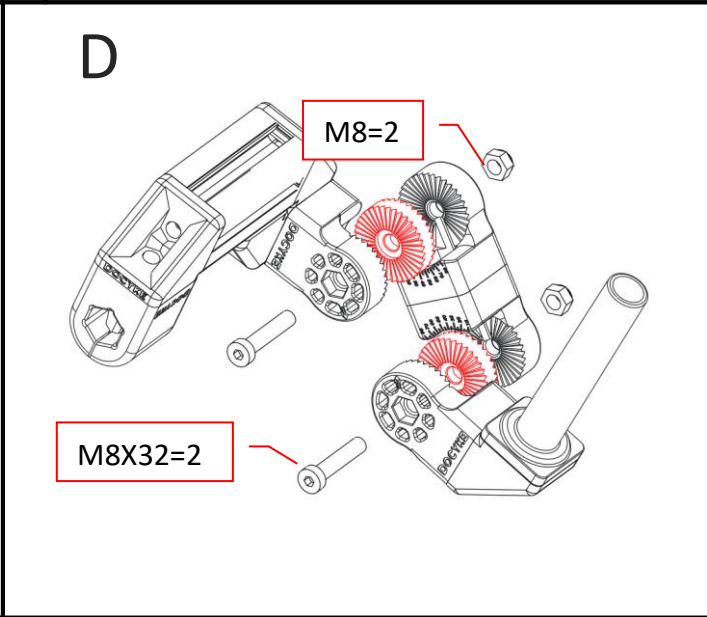
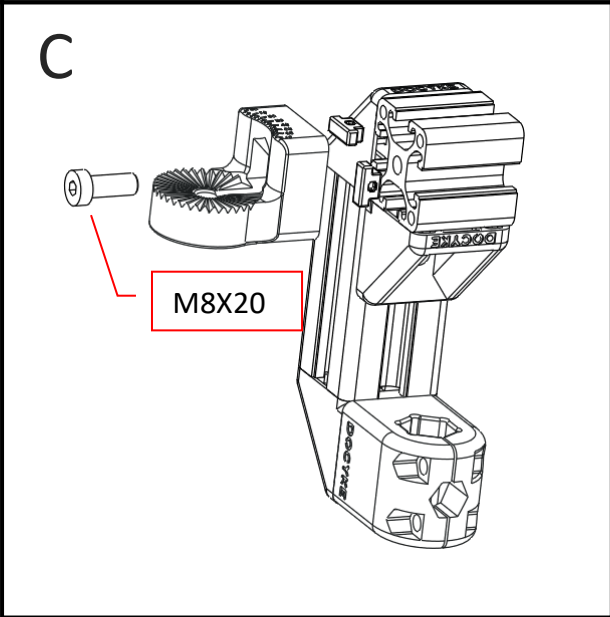
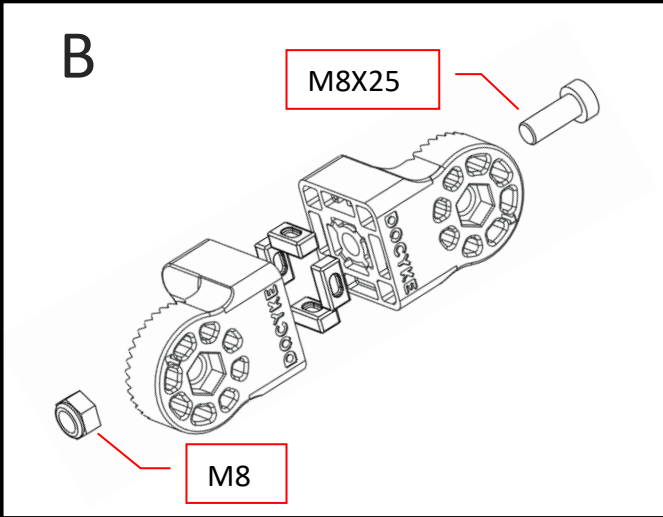
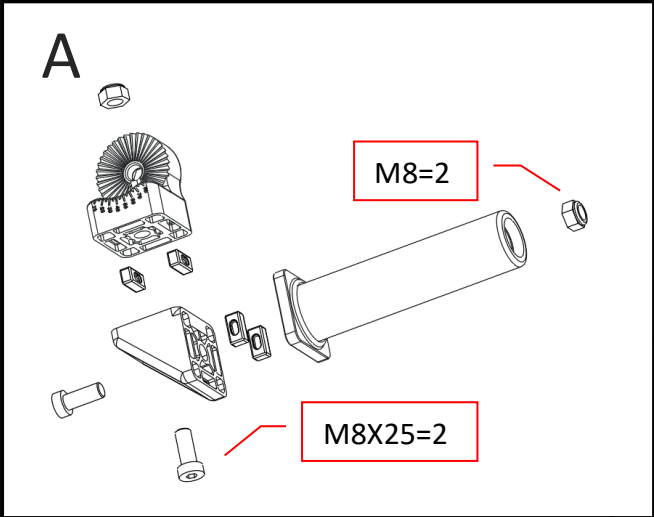
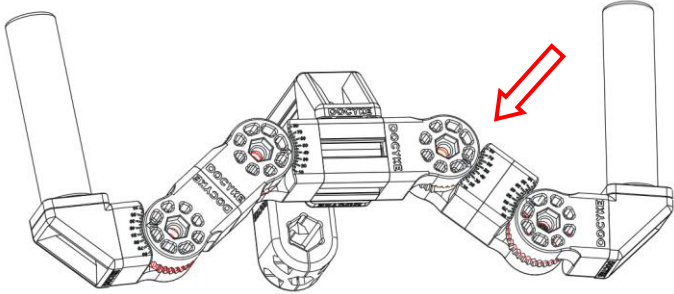

Ponovite te korake in sestavite drugo stran.

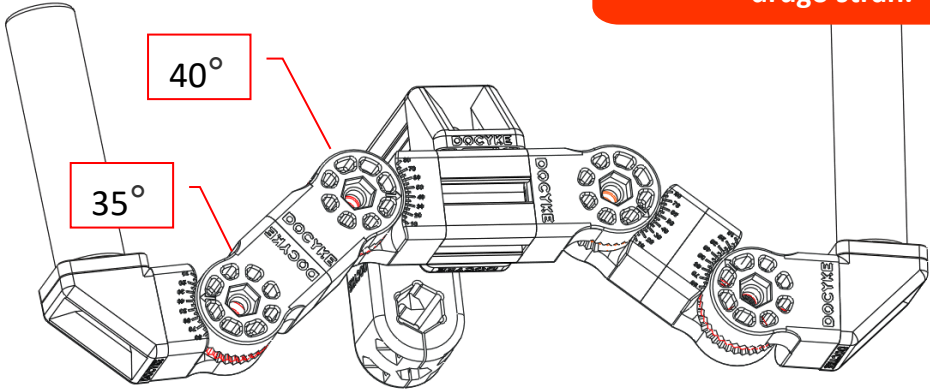



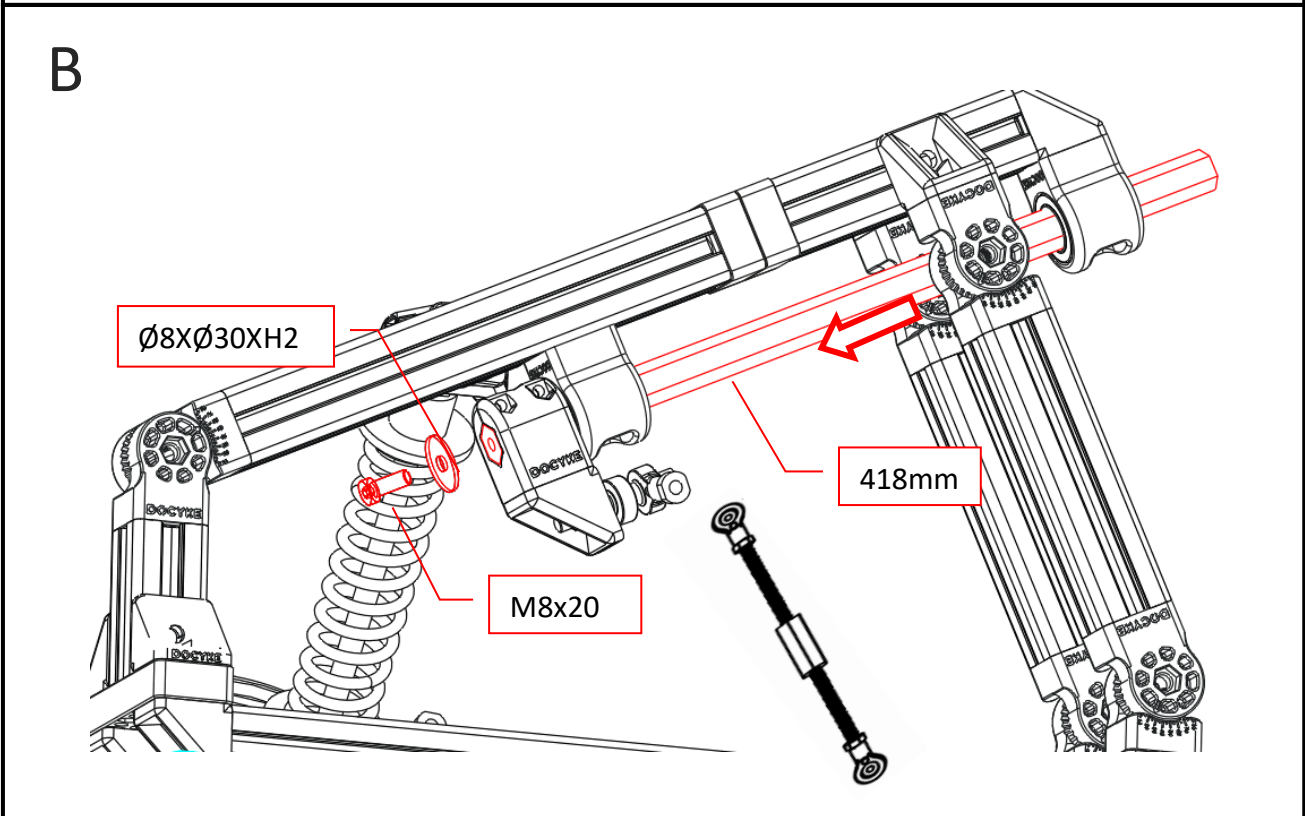
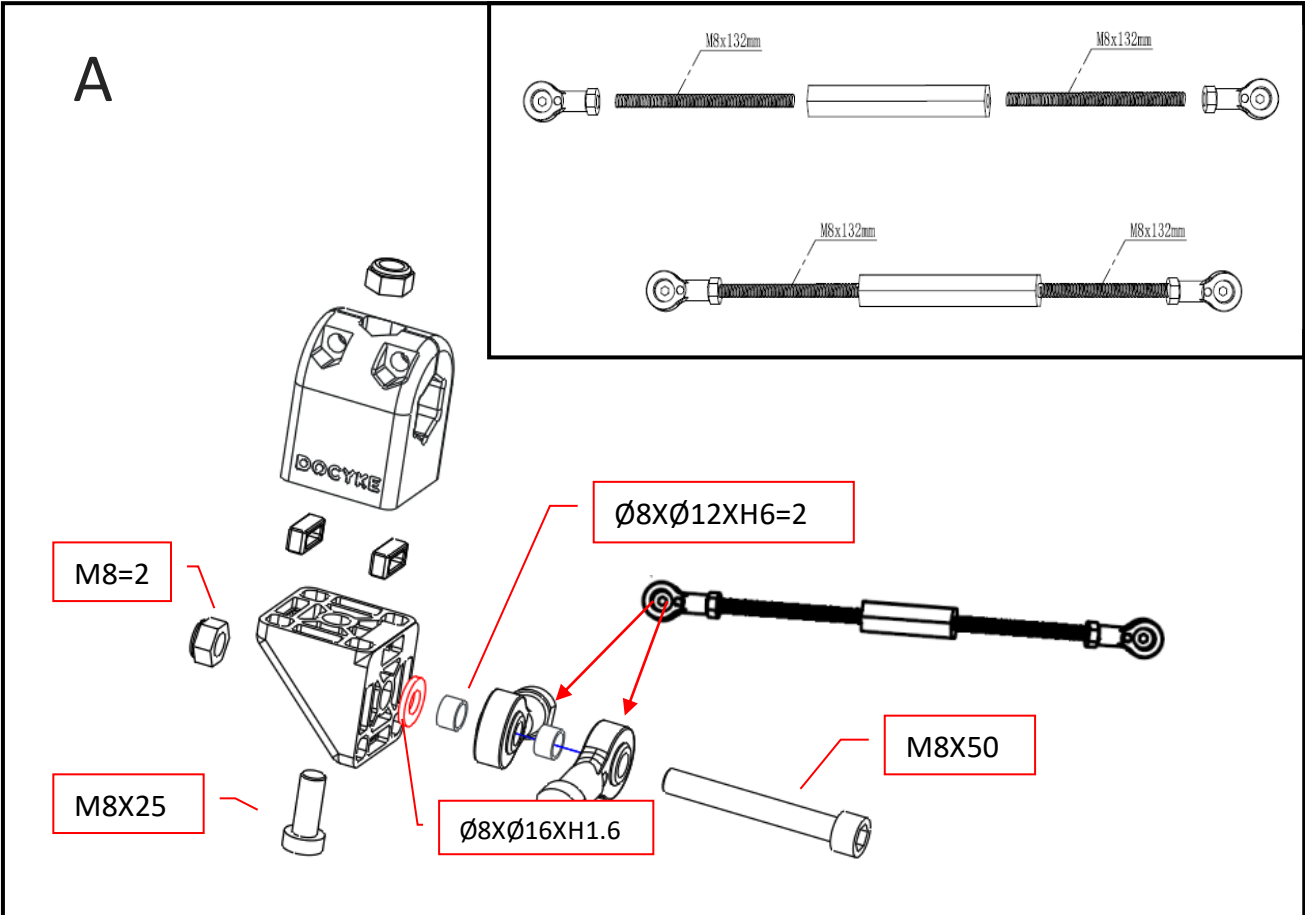
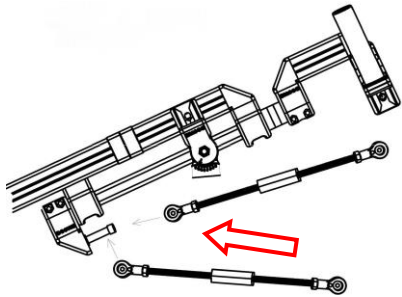



A

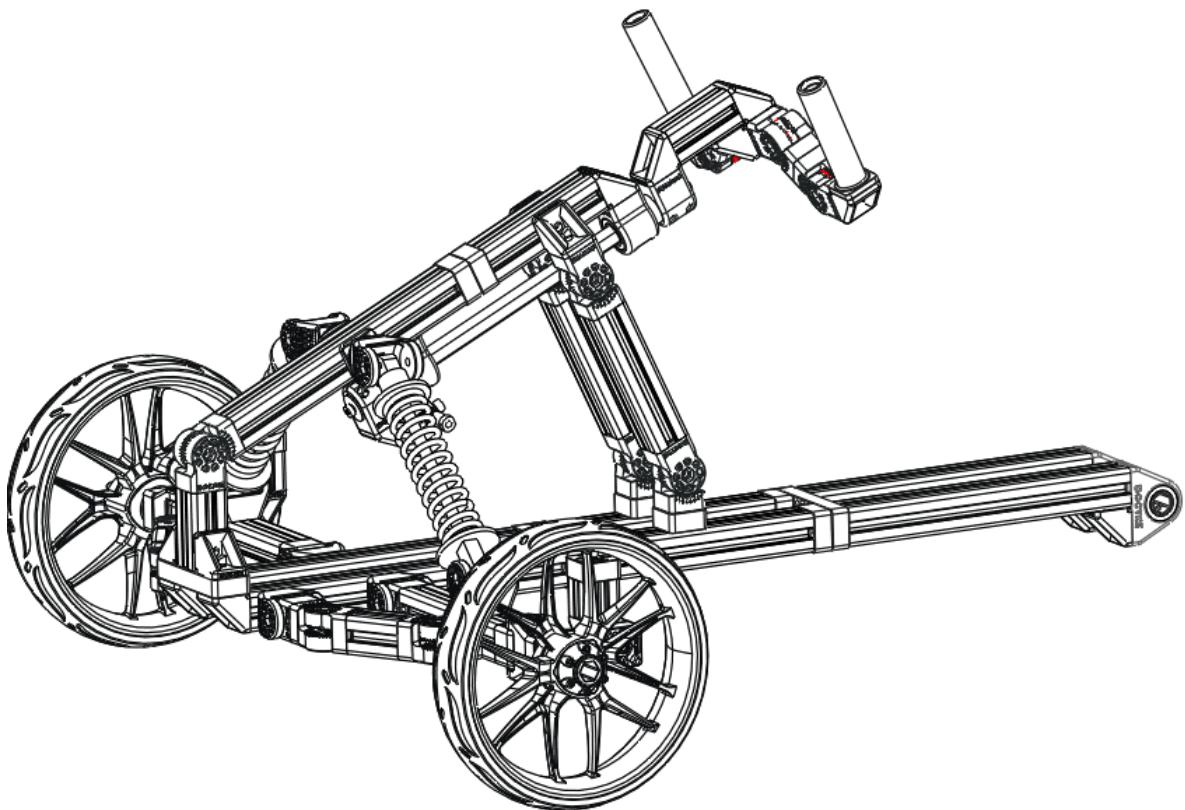
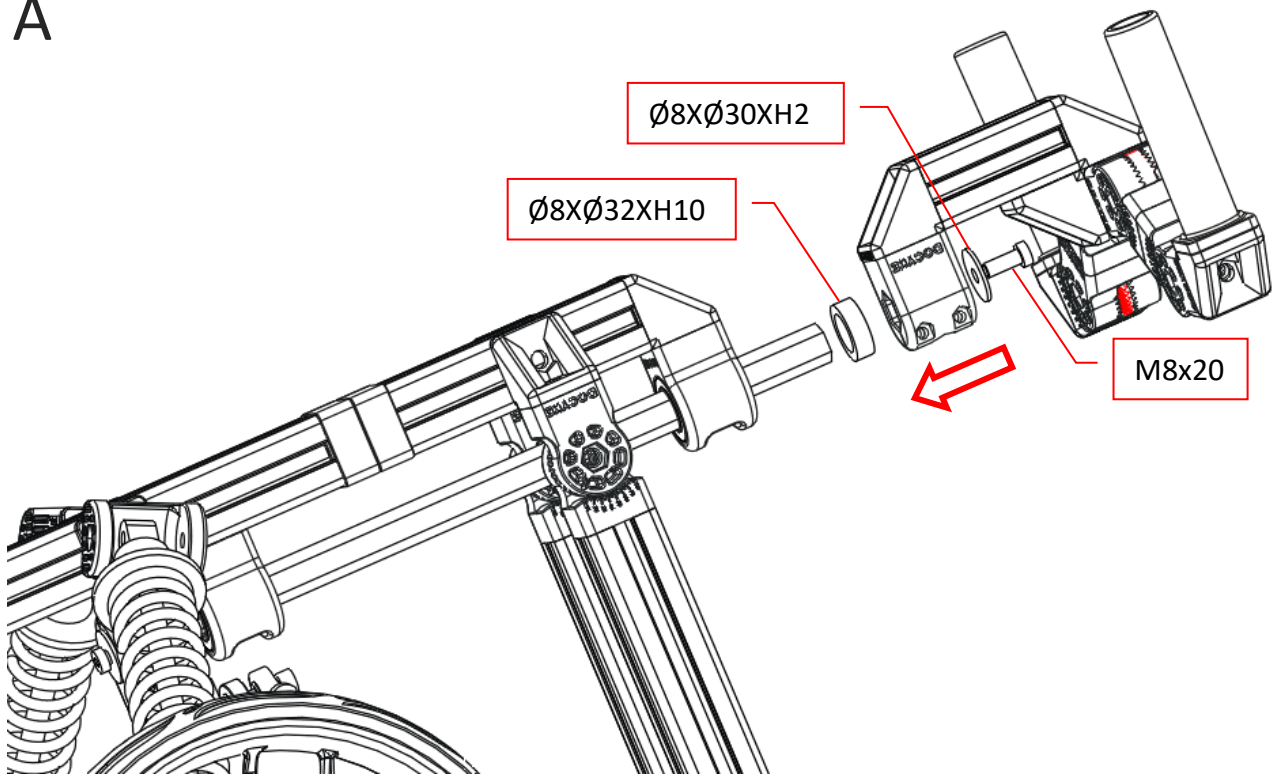

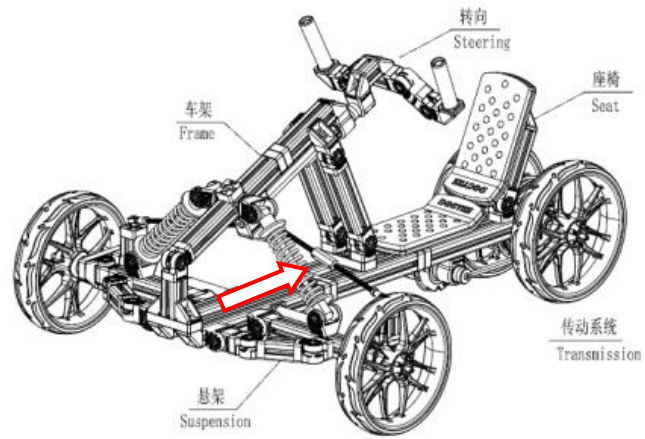

Preverite, da sta kolesa vzporedna ko oseba sedi na sedežu.

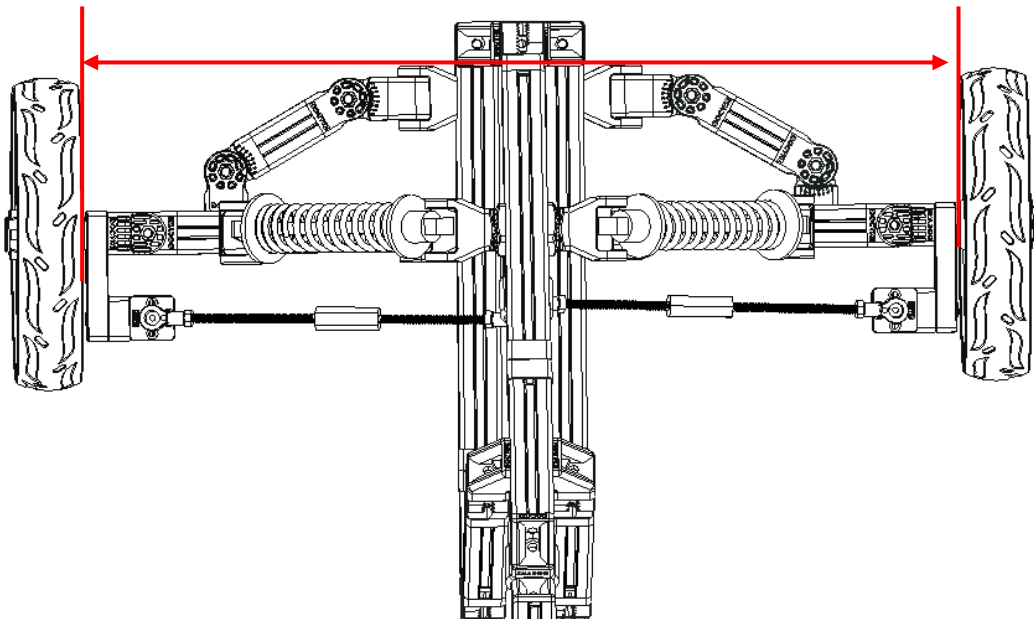

25

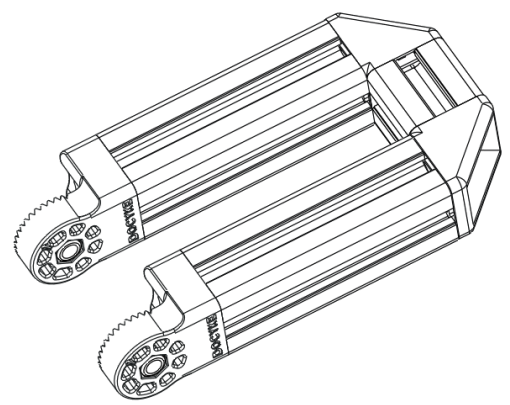
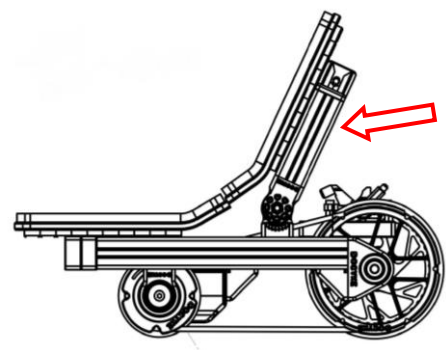
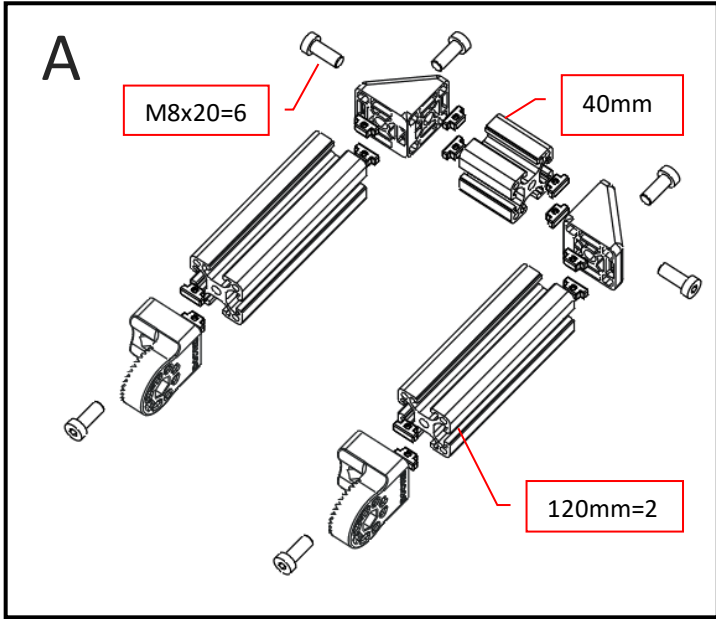

26

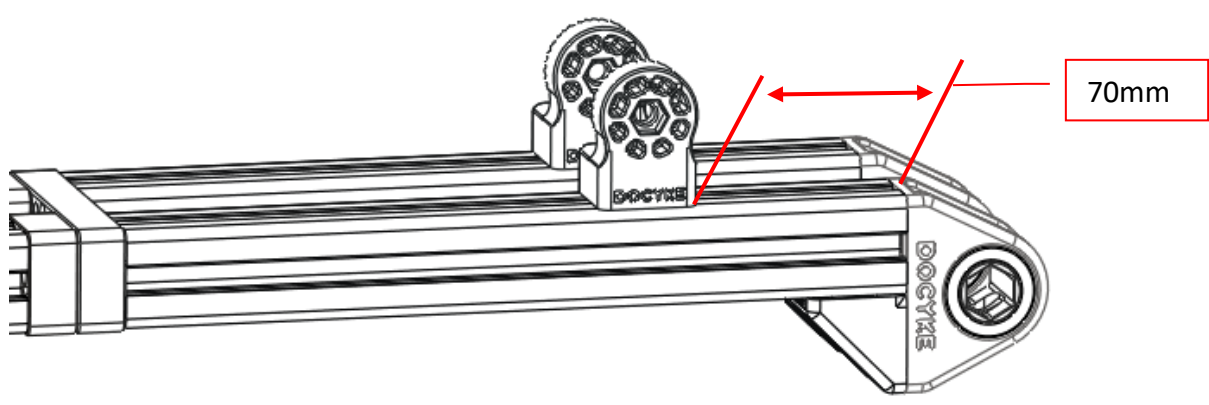
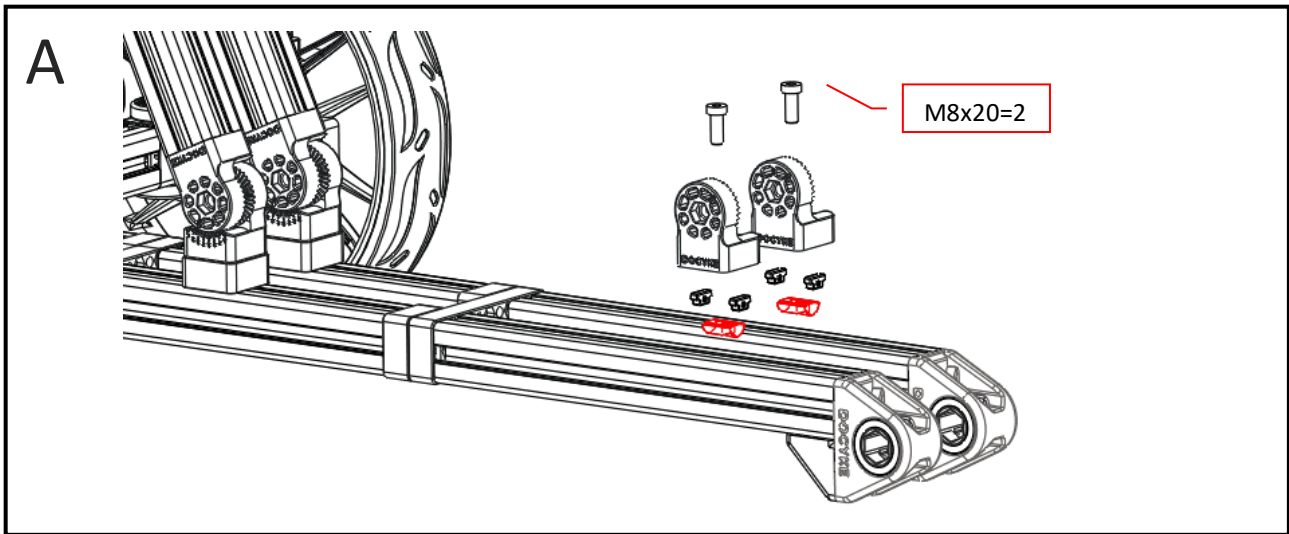

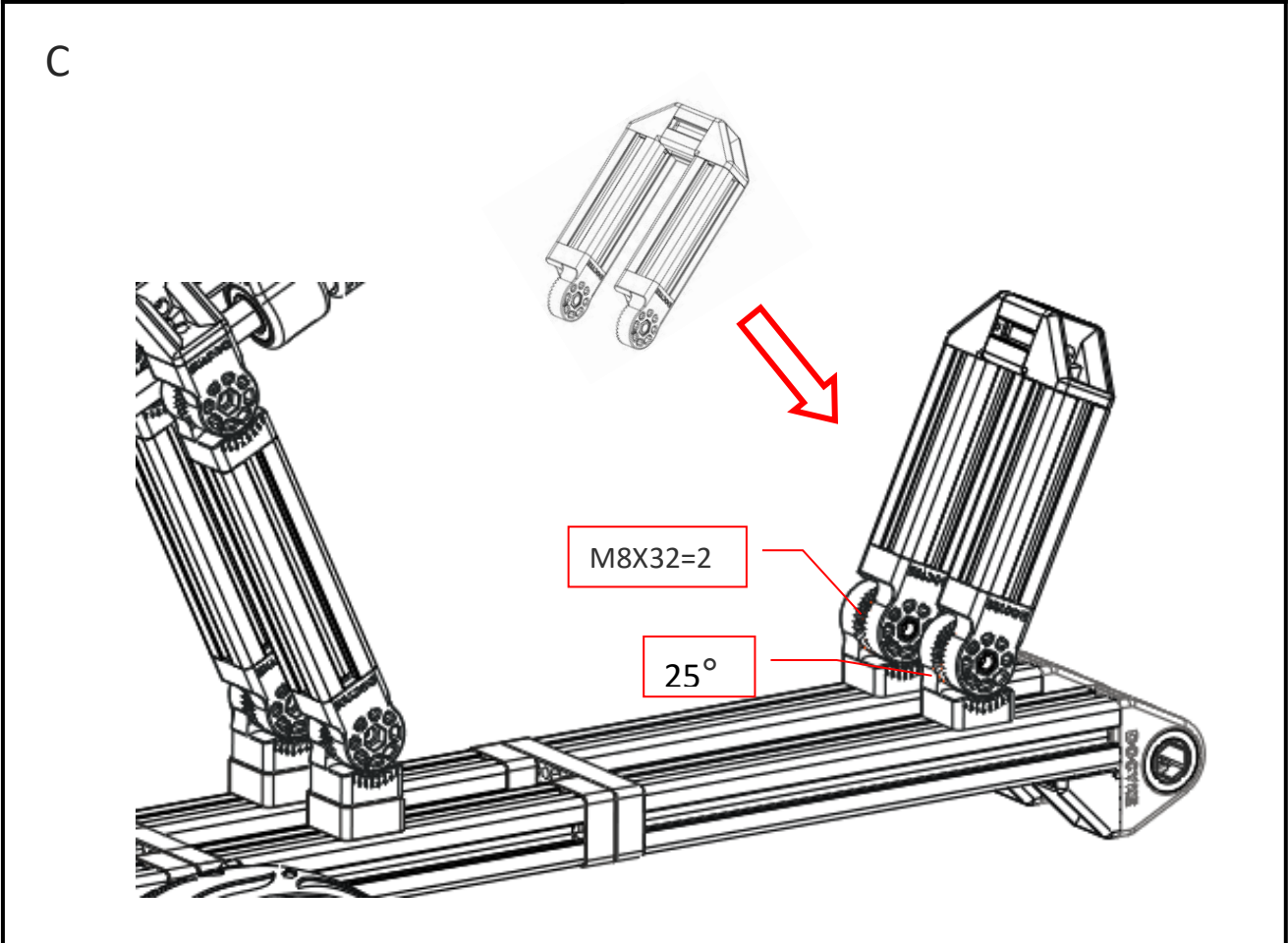
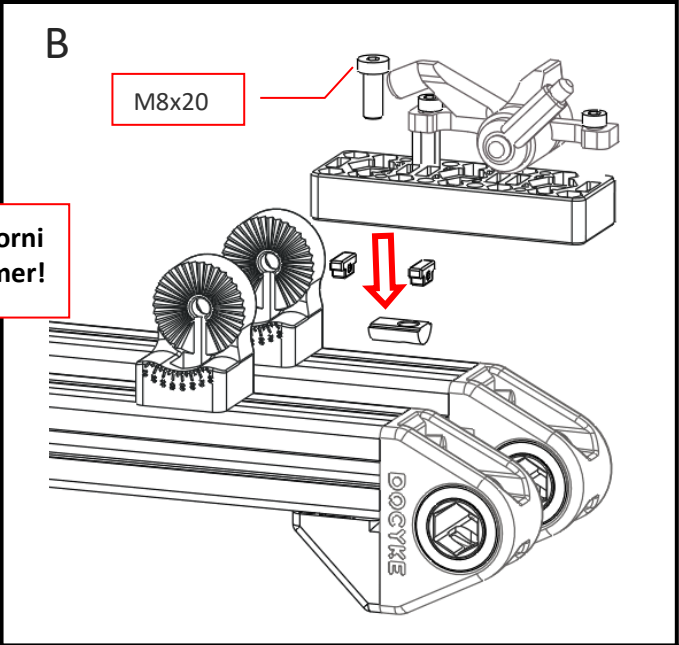
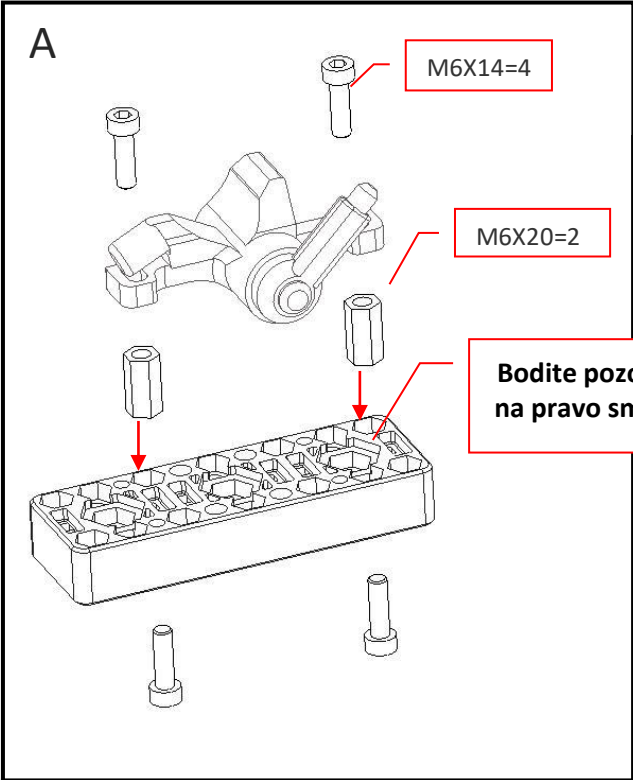
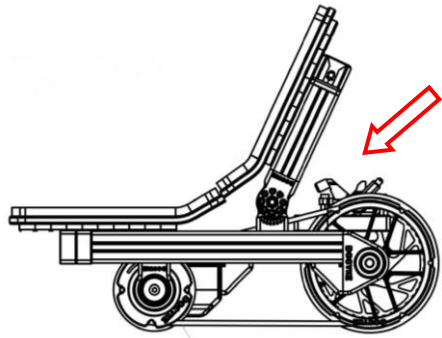



A

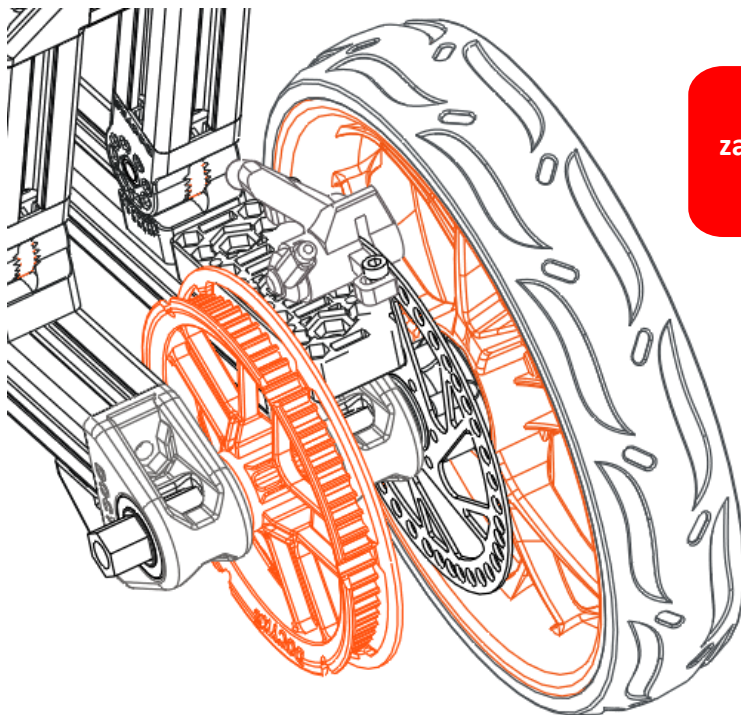
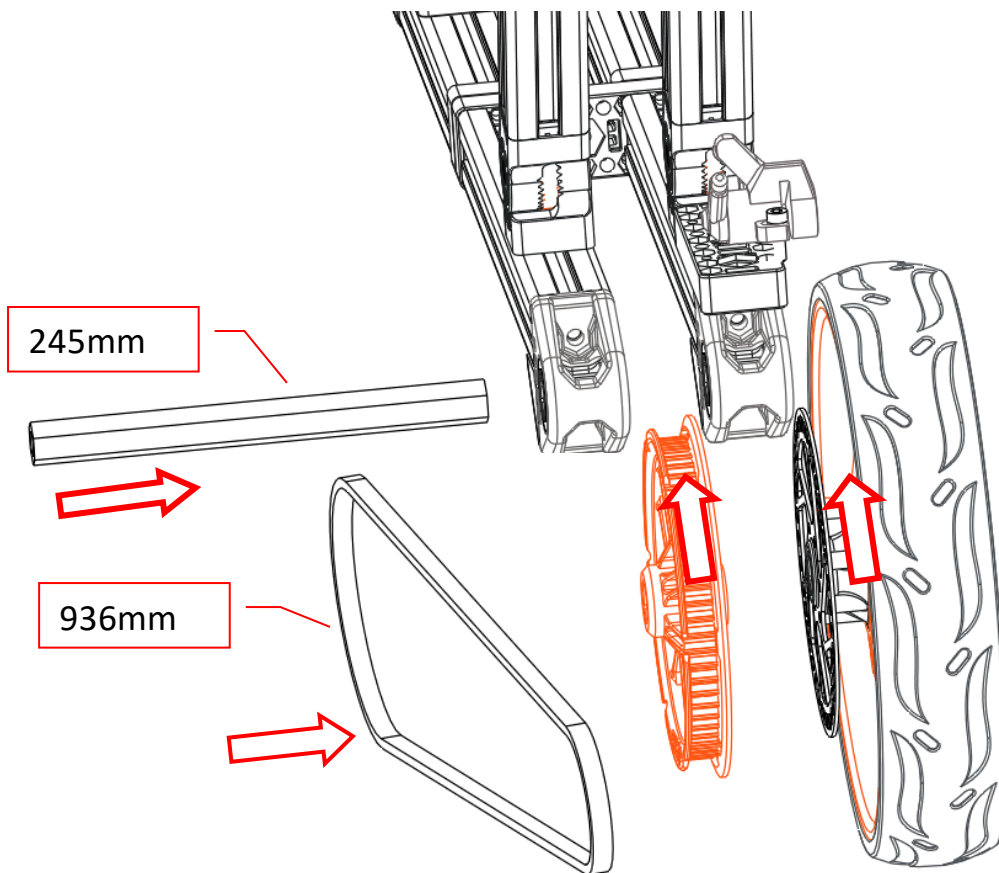

**Namestite razmik med zavorami in zavornim diskom ter privijte vijake.**

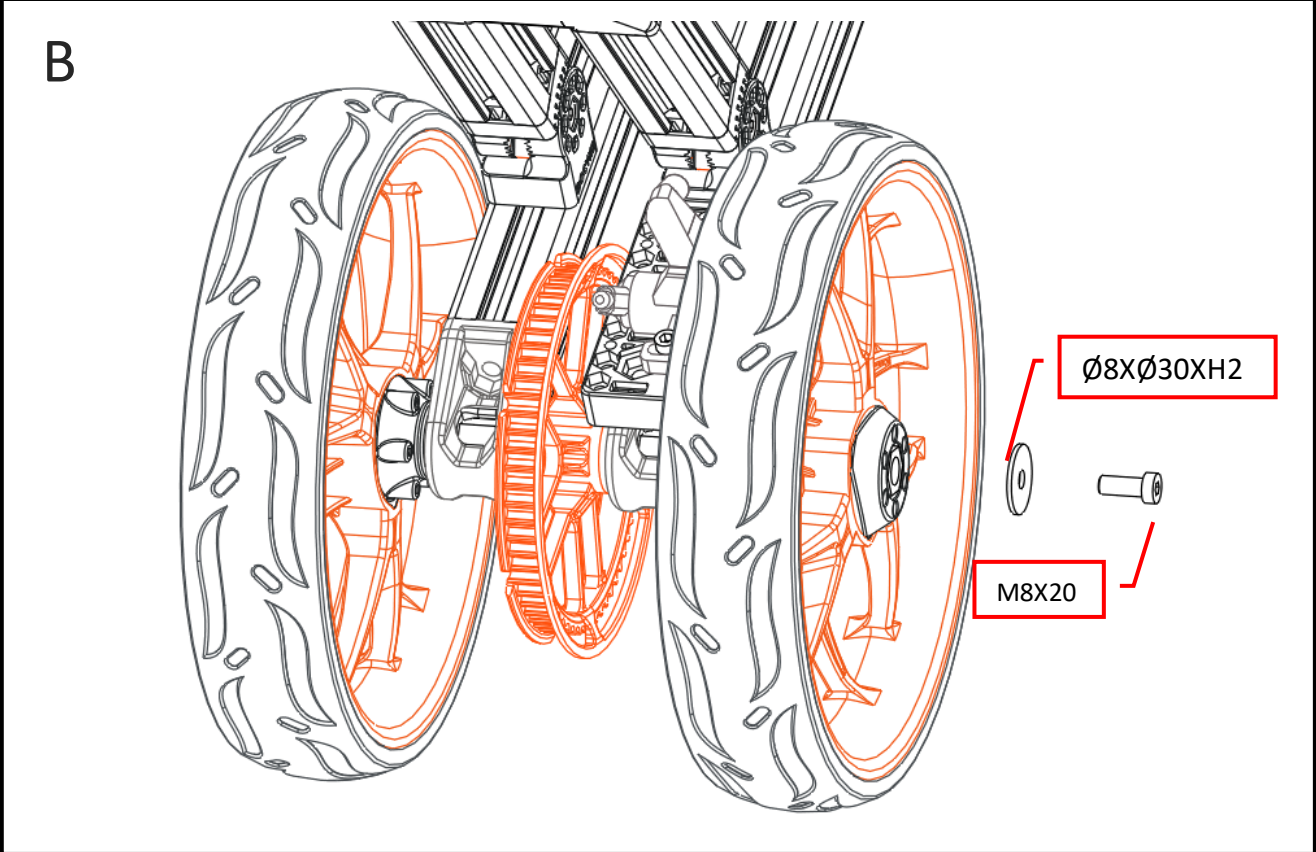
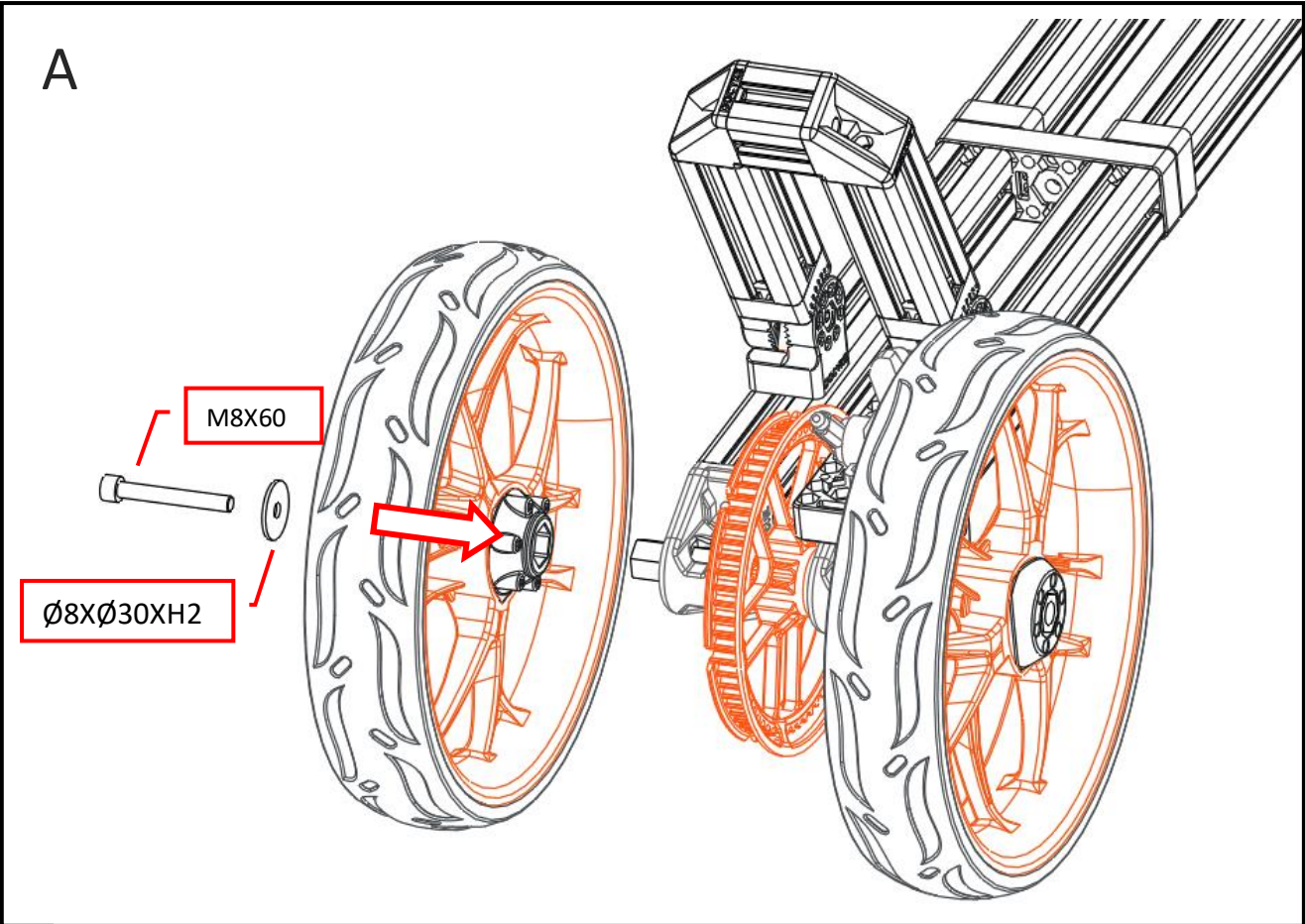

30

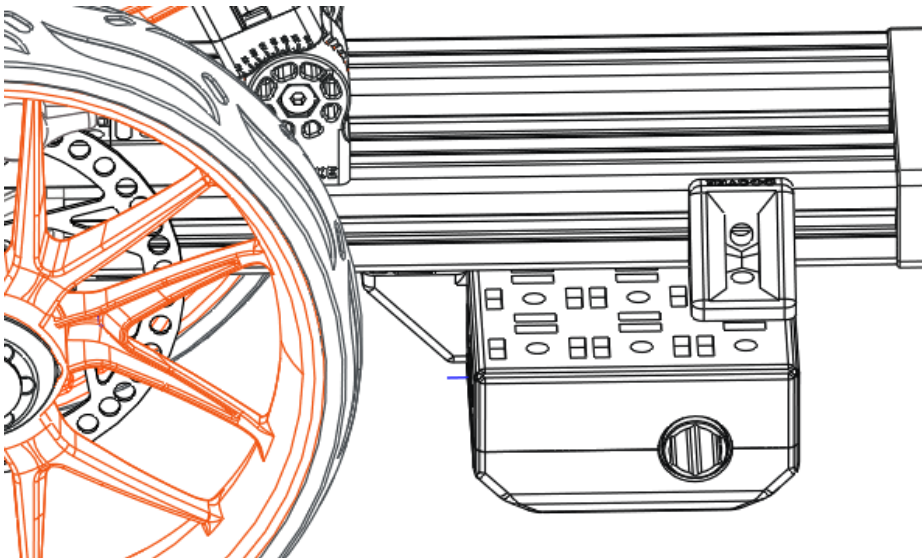
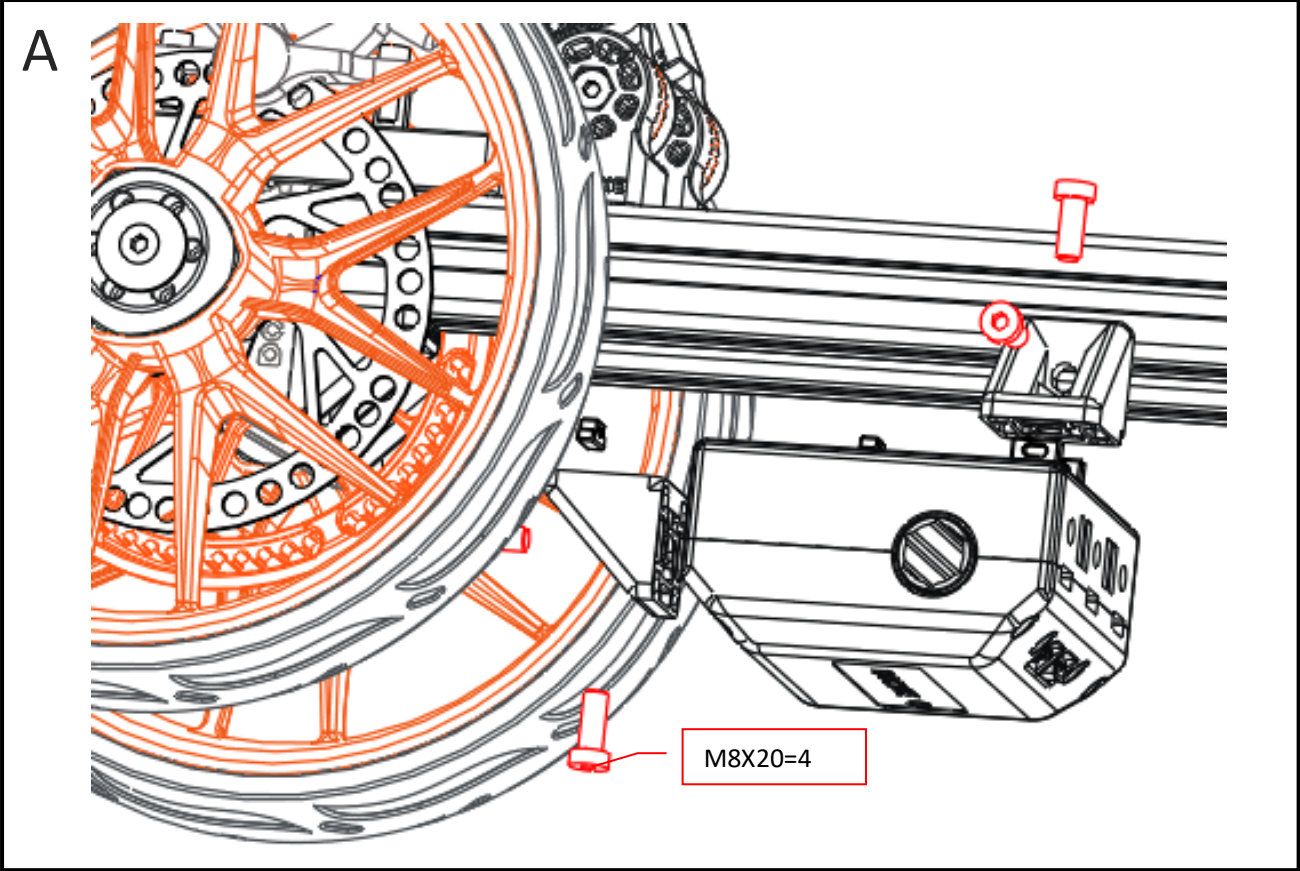
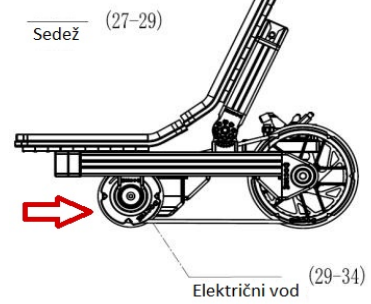
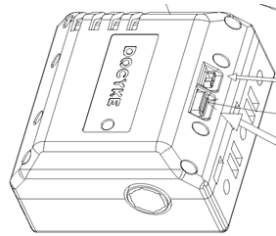

**Napnite nazobčen jermen s polno silo in dobro privijte vijake.**



Napnite nazobčen jermen s polno silo in dobro  
privijte vijake.

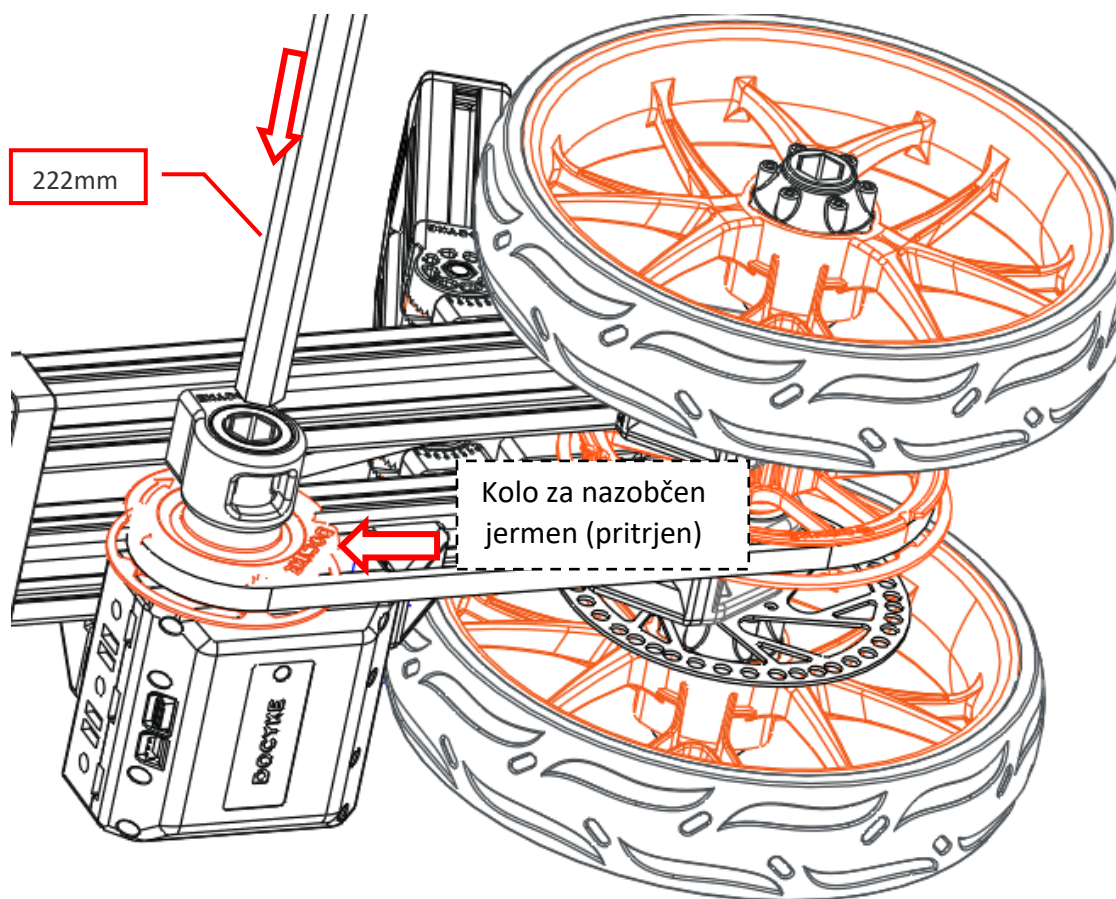
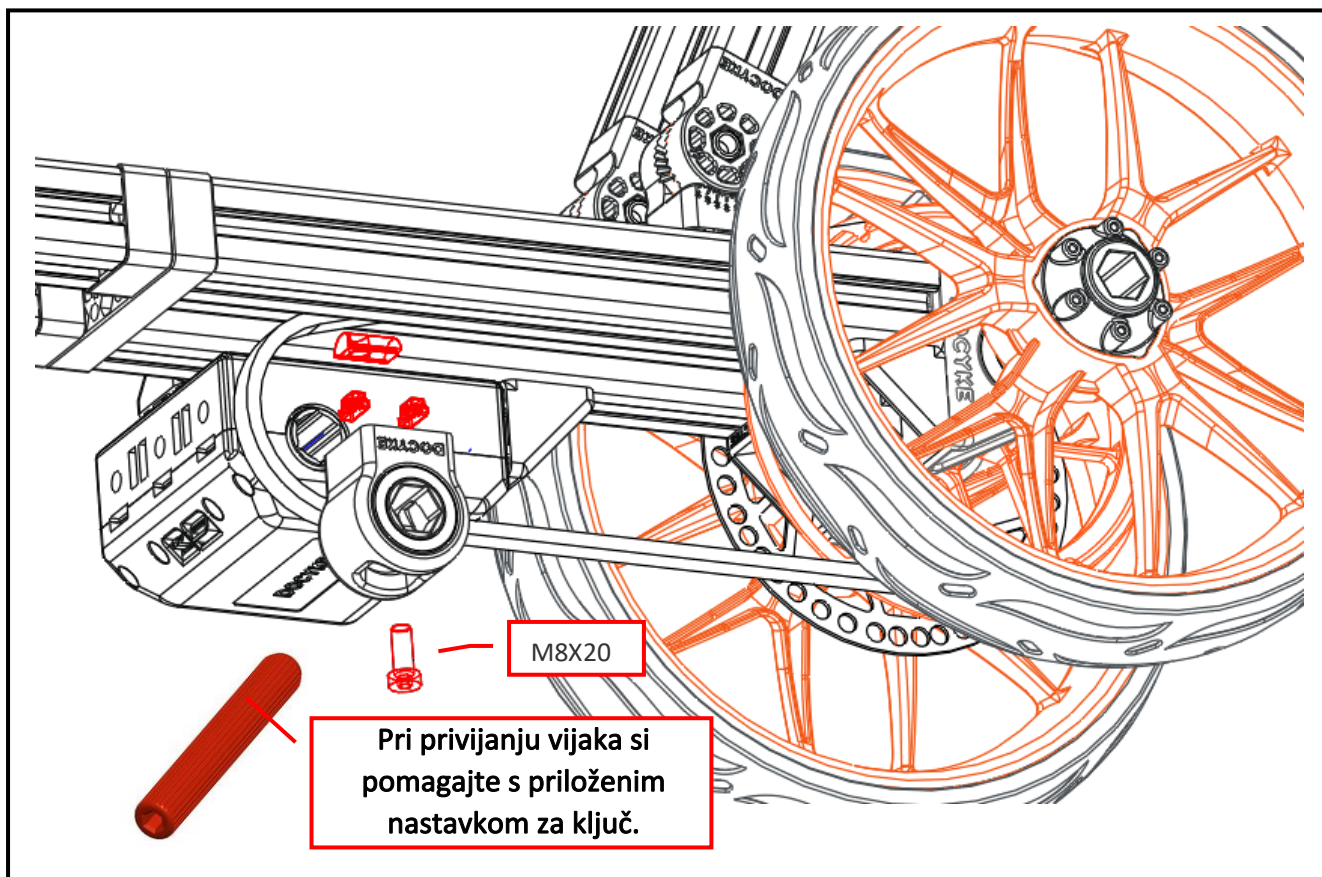



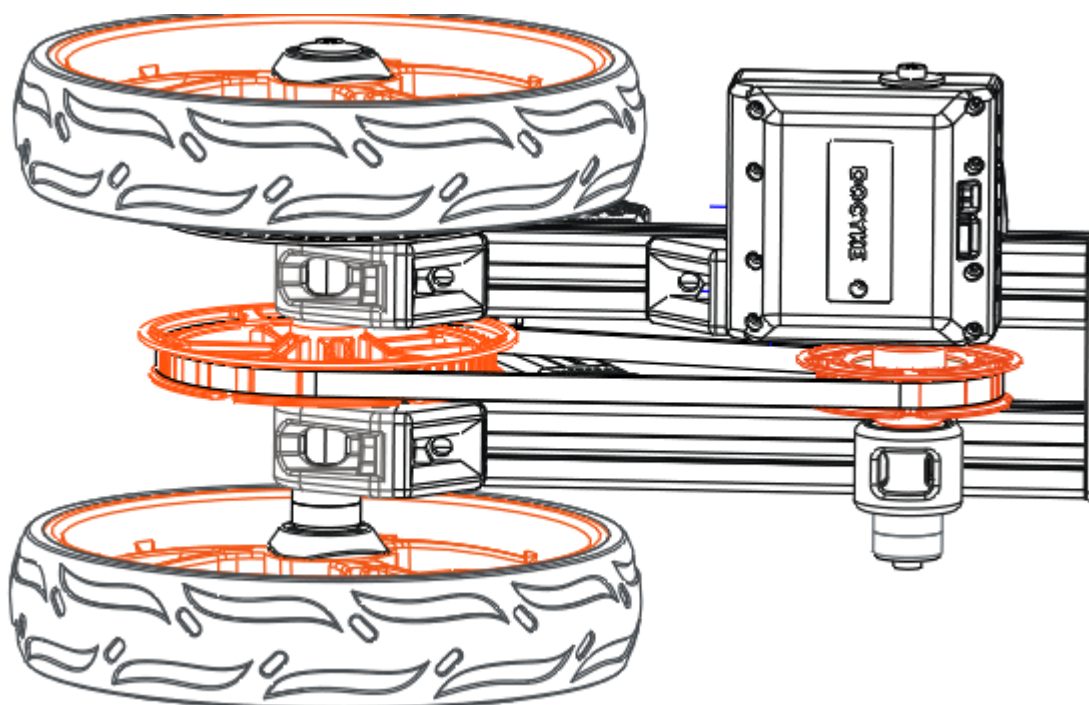
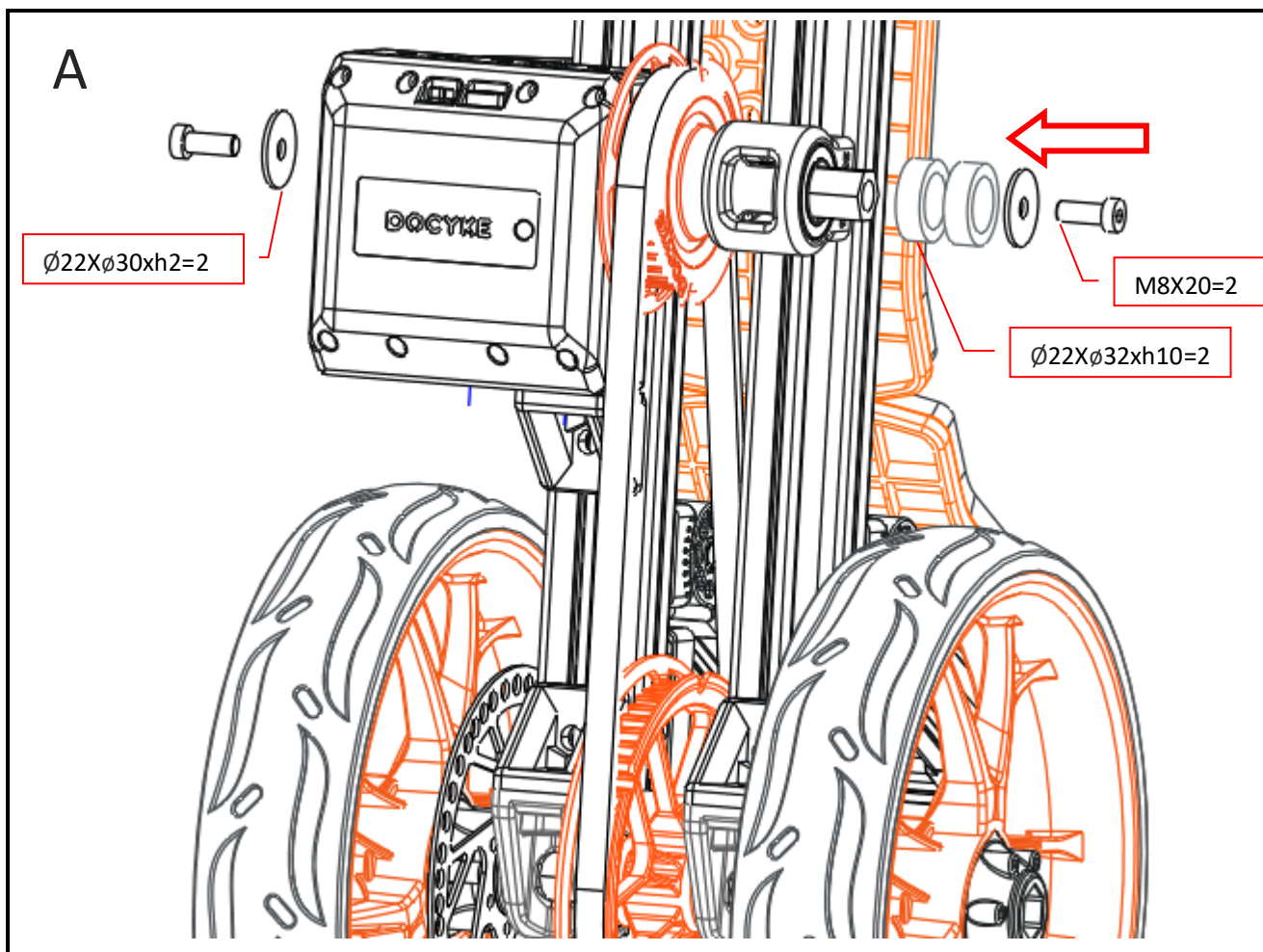

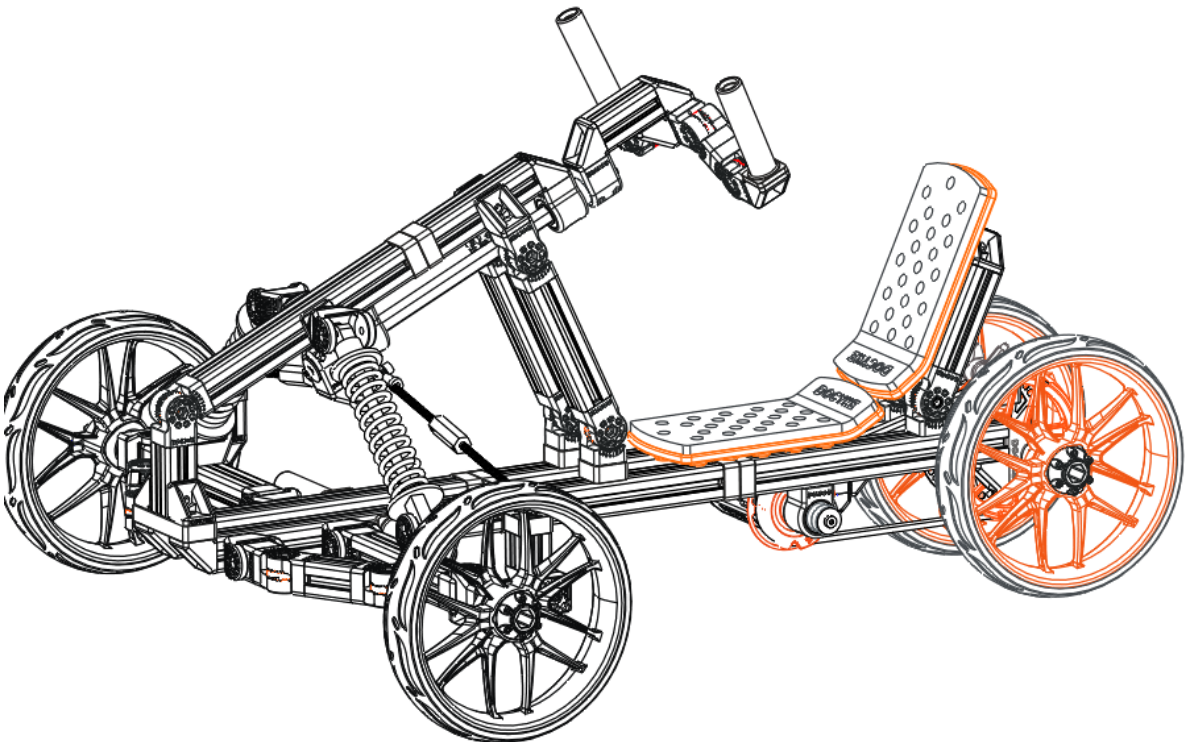
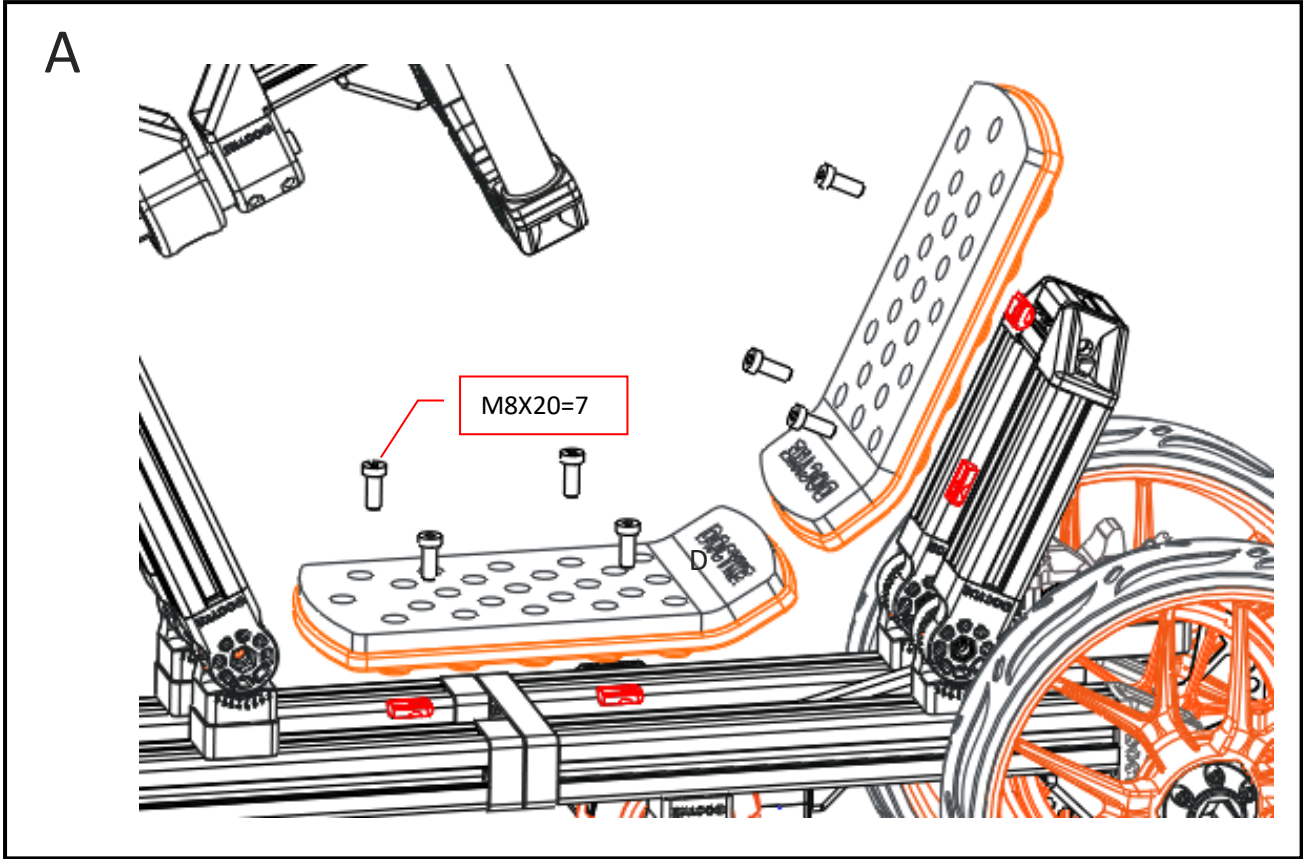
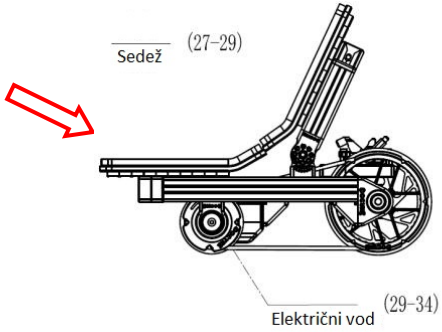

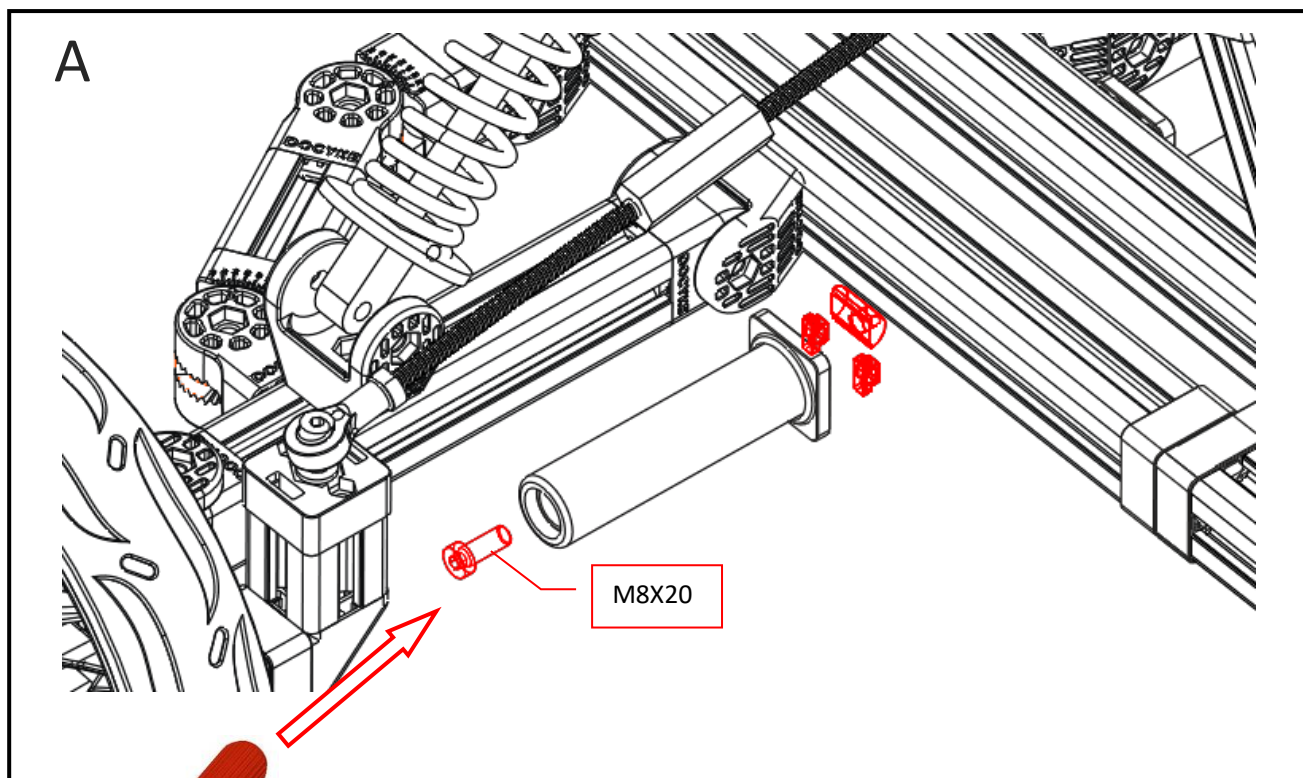

Pri privijanju vijaka si pomagajte s priloženim nastavkom za ključ.

Ponovite korake na drugi strani.

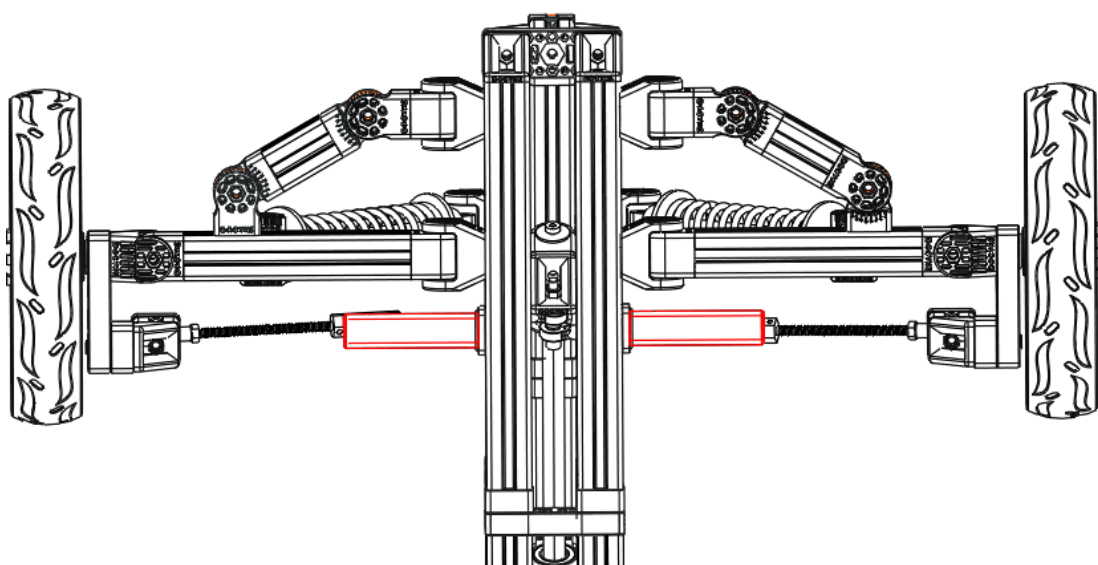



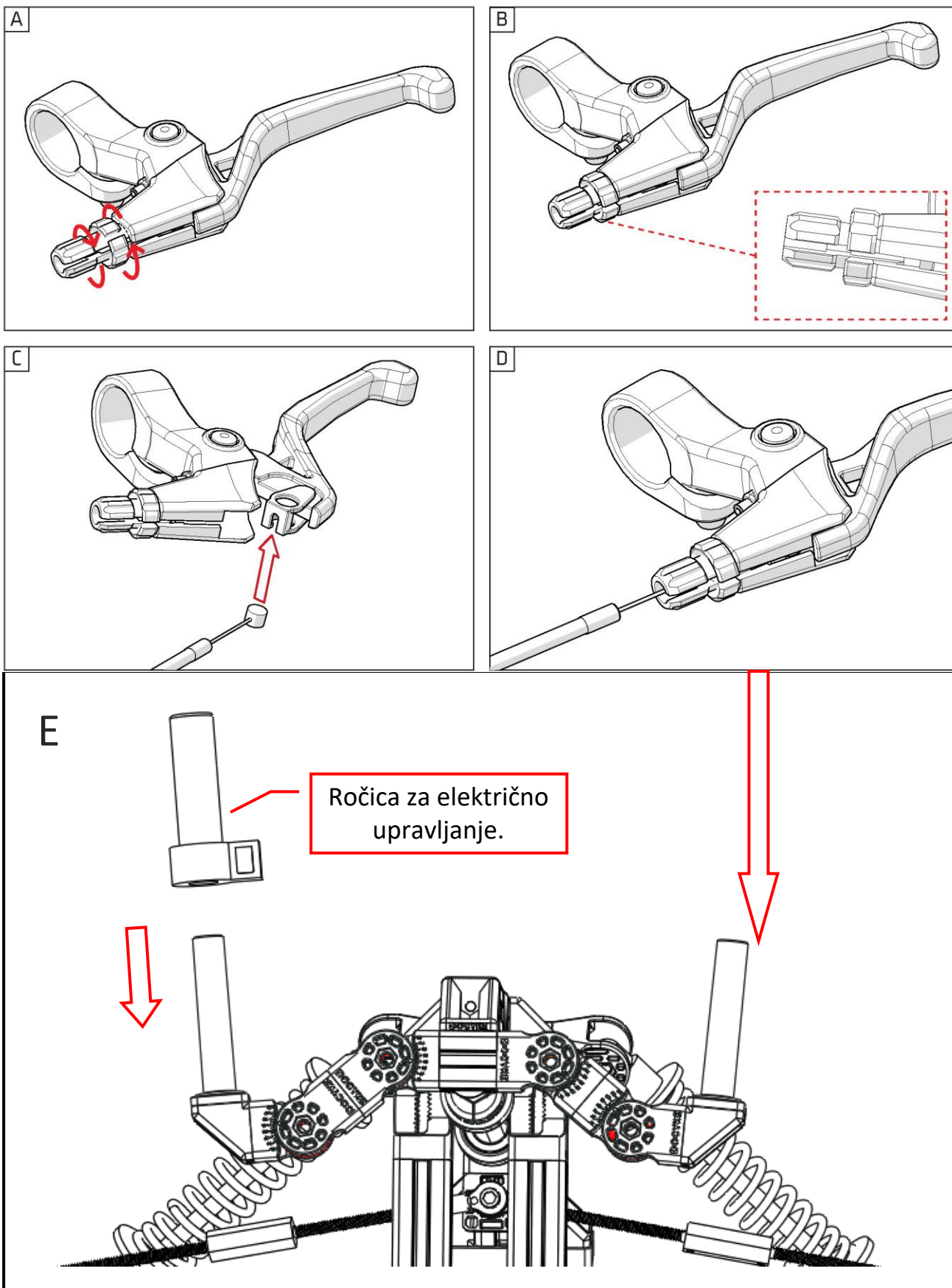



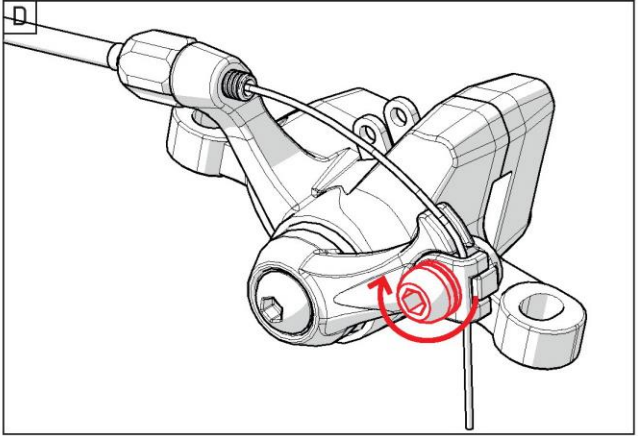
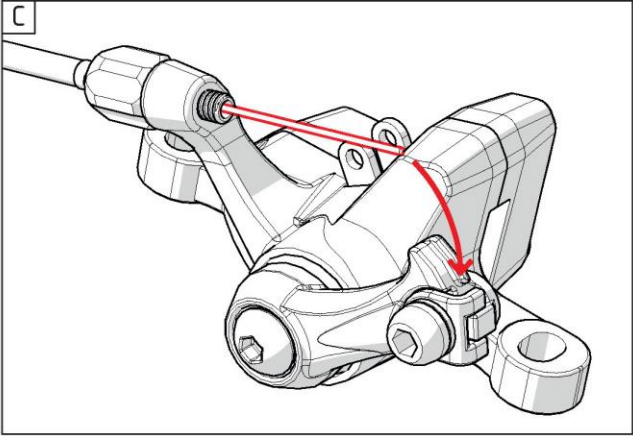
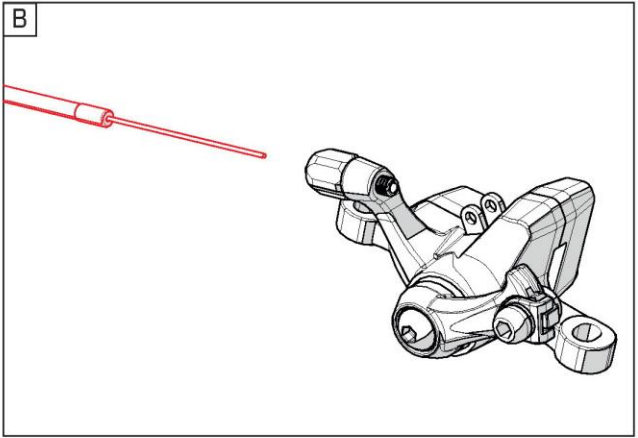
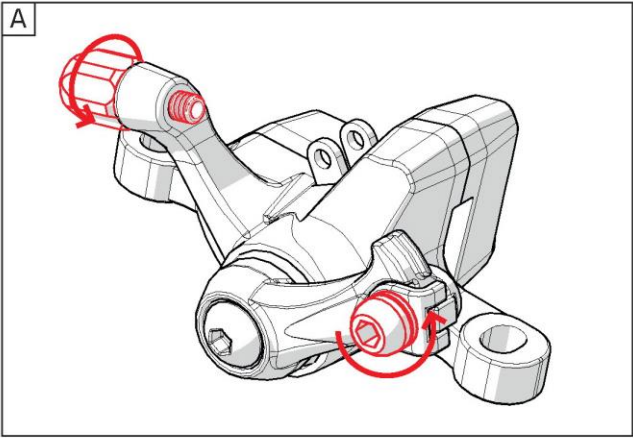
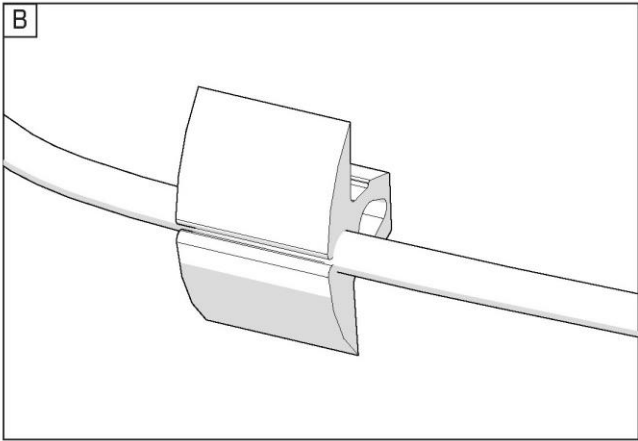
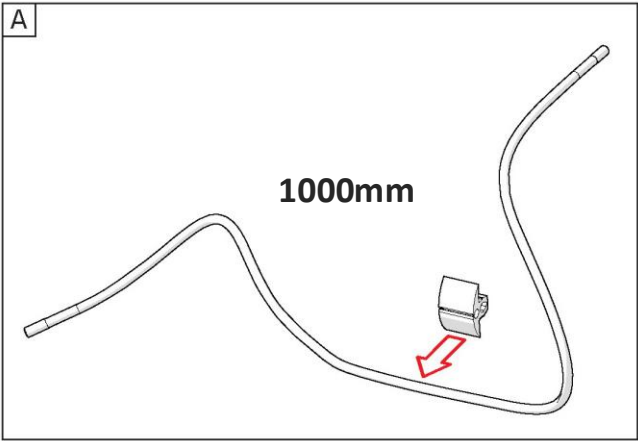

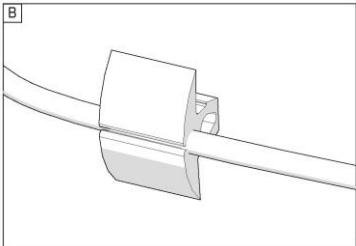
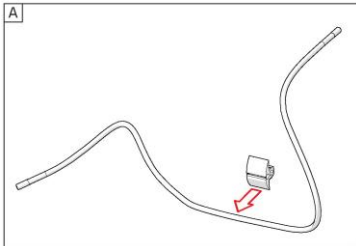
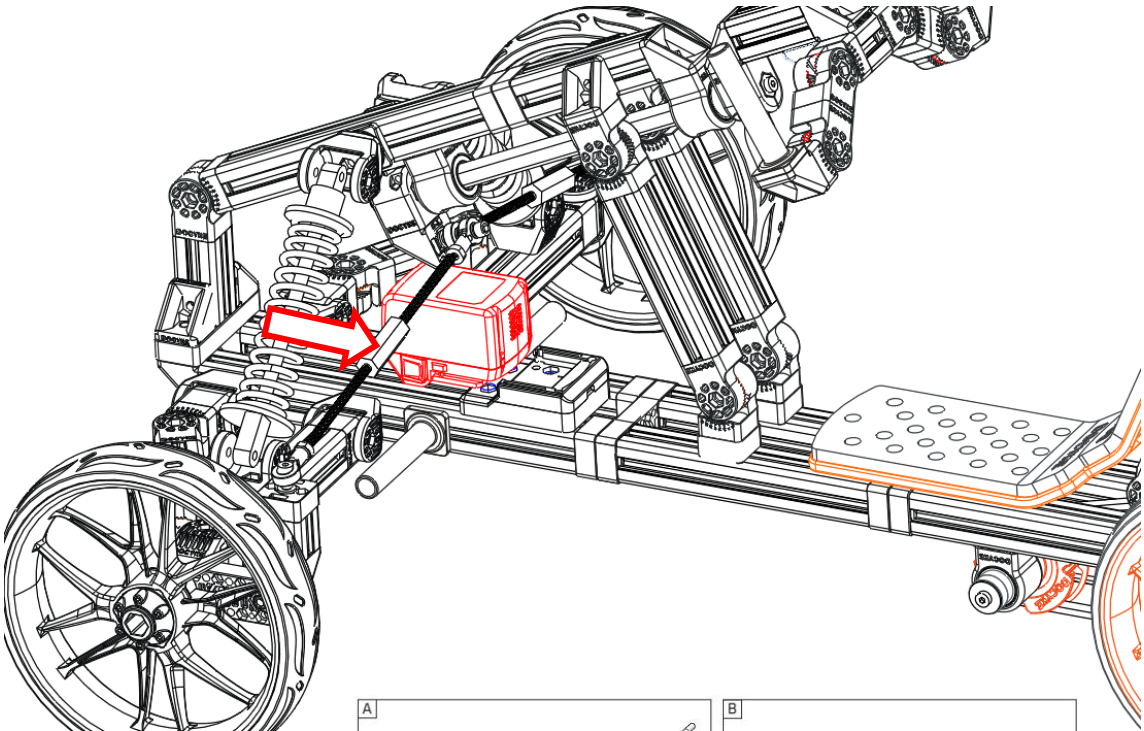
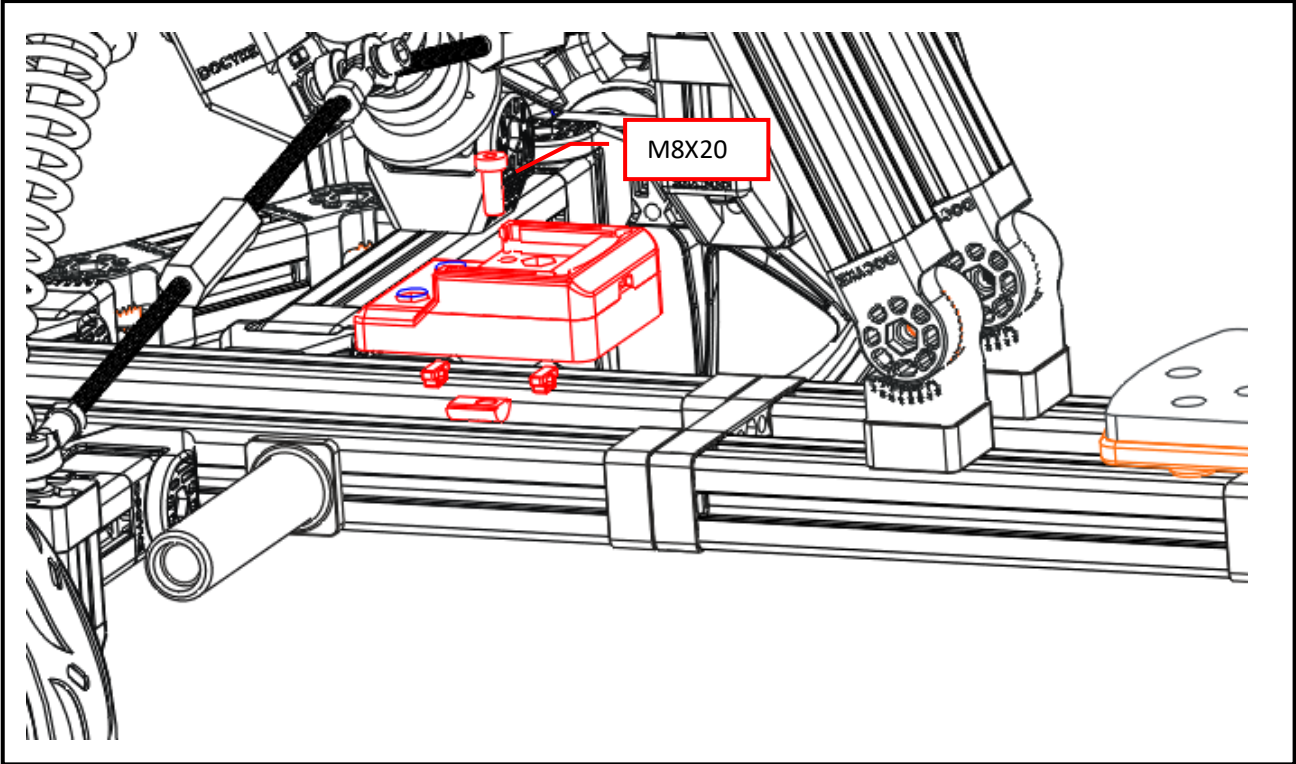

## Navodila za priklop motorja

Elektromotorni pogon

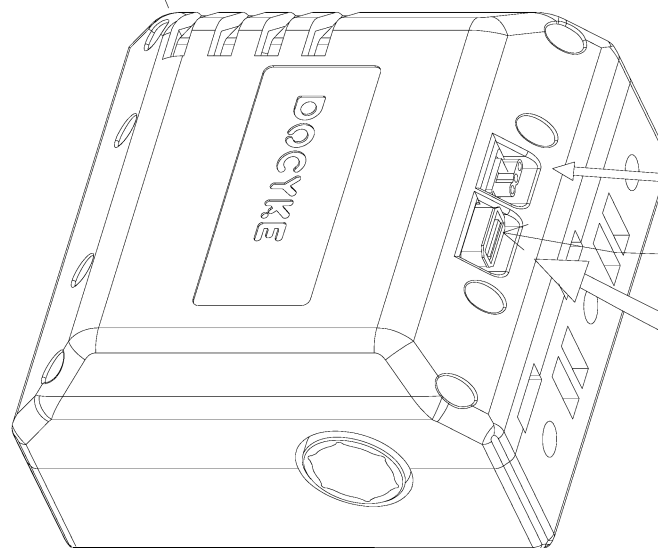

Priklopno ohišje za Li baterijo

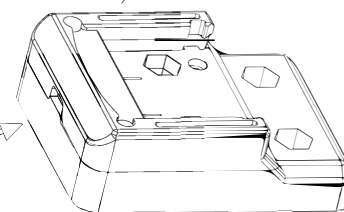

- Li baterija

DOCYKE

Napajalni kabel

Ročica za električno upravljanje I/O:  
poskrbite za zanesljivo povezavo in čistočo,  
sicer lahko pride do okvare

Vijak za pritrditev ročice

Stikalo za upravljanje smeri vožnje  
(naprej/nazaj)

Ročica za električno upravljanje  
in nadzor hitrosti

Varnostno stikalo za vklop/  
aktivacijo elektromotorja

Predstavitev elektromotornega sklopa

1. Visoko zmogljivi brezkrtačni motor, nazivna moč 400W, max. izkoristek 86%
2. Varnostna zaščita (blokada, zaščita proti pregrevanju, pretokovna zaščita, prenapetostna zaščita)
3. Elektronska zavora (s stikalom naprej/nazaj lahko zaviramo ali prekinemo zaviranje)
4. Li baterija po 10 sekundah mirovanja preklopi v stanje varčevanja)
5. Zmogljivosti Li baterije: 6Ah
6. Hitri polnilec Li baterije: 220-230VAC (predviden polnilni čas 3h)

# GK-01

Največja dovoljena teža 50kg

